

A181 Benchtop Dissolved Oxygen Meter

# **Instruction Manual**

## Introduction

Thank you for selecting the A181 benchtop dissolved oxygen meter. This manual provides a step-by-step guide to help you operate the meter, please carefully read the following instructions before use.

## Unpacking

Before unpacking, ensure that the current work environment meets following conditions.

- Relative humidity is less than 80%.
- Ambient temperature is greater than 0°C and less than 60°C.
- No potential electromagnetic interference.

The following list describes the standard components of the meter. After the unpacking, please check all components are complete. If any are damaged or missing, please contact nearest distributor.



A181 Dissolved Oxygen Meter

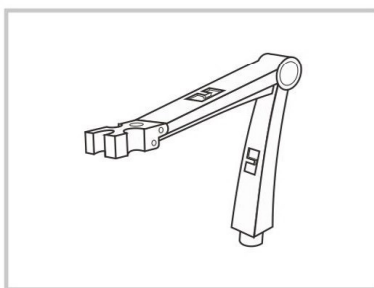

Electrode Holder



DO100 Dissolved Oxygen Probe



Electrolyte Solution





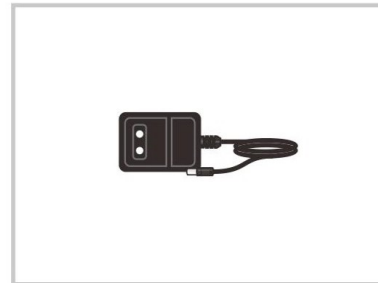



Membrane Cap

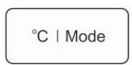
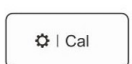

DC12V Power Adapter

### Keypad

The A181 meter has a succinct membrane keypad, names and symbols describe the each function key controls.

KEY	FUNCTION
	<ul style="list-style-type: none"> <li>• Switches the meter ON/OFF.</li> <li>• Exits the calibration or setting and returns to measurement.</li> </ul>
	<ul style="list-style-type: none"> <li>• Selects the measurement mode.</li> <li>• Sets the temperature (Press and hold the key for 3 seconds).</li> </ul>
	<ul style="list-style-type: none"> <li>• Starts calibration.</li> <li>• Enters the setup menu (Press and hold the key for 3 seconds).</li> </ul>
	<ul style="list-style-type: none"> <li>• Locks the measured value.</li> <li>• Resume measuring.</li> </ul>
	<ul style="list-style-type: none"> <li>• Sends data to a printer or computer.</li> </ul>
	<ul style="list-style-type: none"> <li>• Stores current reading to memory.</li> <li>• Increase value or scroll up through the menu item.</li> </ul>
	<ul style="list-style-type: none"> <li>• Views the calibration report or data logs.</li> <li>• Decrease value or scroll down through the menu item.</li> </ul>
	<ul style="list-style-type: none"> <li>• Confirms the calibration, settings or displayed options.</li> </ul>

### Connectors

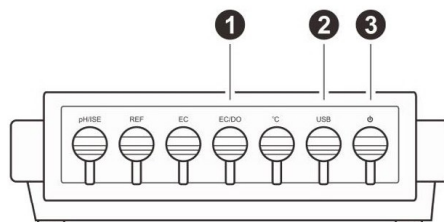

NO.	CONNECTOR	DESCRIPTION
1	EC/DO	Used for connecting the dissolved oxygen probe
2	USB	Used for connecting the computer or printer
3		Used for connecting the power adapter

## Filling the Electrolyte Solution

1. Take out the dissolved oxygen probe and electrolyte solution from the packaging. Unscrew the membrane cap.
2. Fill the membrane cap halfway with electrolyte solution.
3. Screw the membrane cap onto the probe, excess electrolyte solution will drain out.
4. Be sure the cathode of probe makes contact with membrane cap, the electrolyte solution in membrane cap should be without an air bubble.

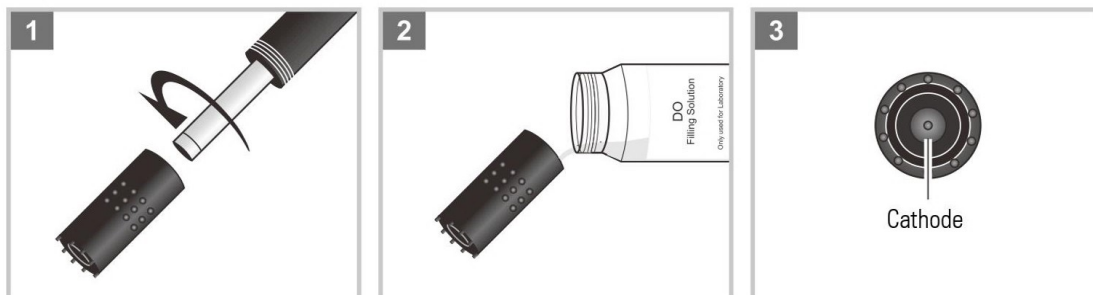

## Installing the Electrode Holder

Take out the electrode holder from the packaging. Turn the meter over. Align the base plate of the electrode holder with the circular holes on the meter. Moderately tighten two screws.

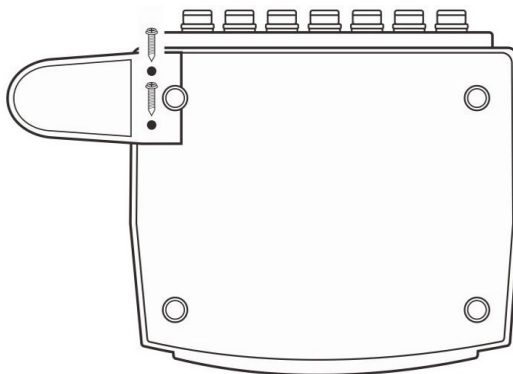

## Adjustment of electrode arm

After installation, if the electrode arm automatically rises or falls, you need to adjust the screw until arm locate at any position.

1. Remove the plastic cover from the electrode arm.
2. Use the screwdriver to tighten the screw moderately.
3. Insert the plastic cover to previous position. Installation is completed.

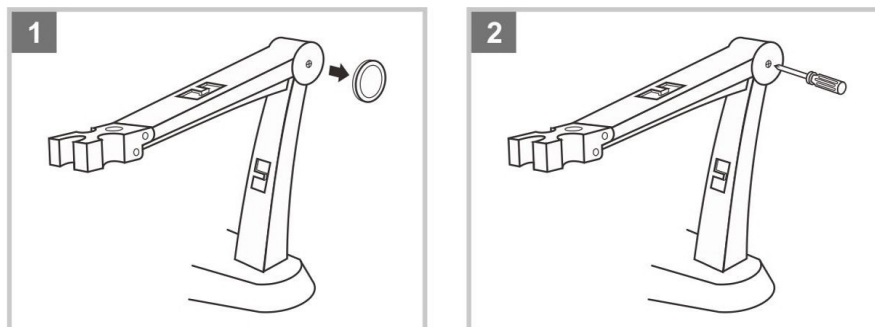

## Connecting the Dissolved Oxygen Probe

1. Insert the 6-pin connector into the connector socket labeled EC/DO. After the connection is completed, DO NOT pull on the cable. Always make sure that the connector is clean and dry.

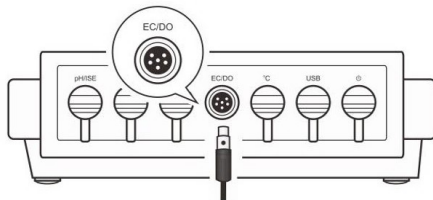

2. Follow the steps below to place the probe into left or right side of the electrode arm.

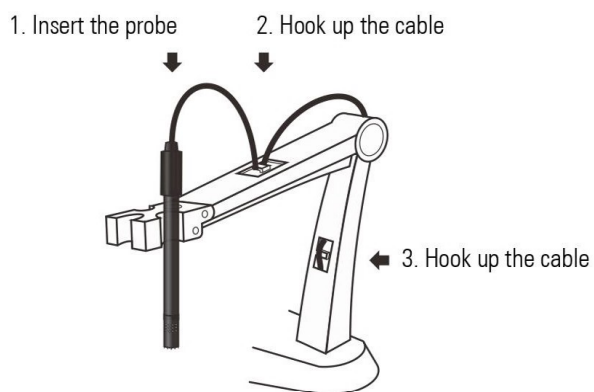

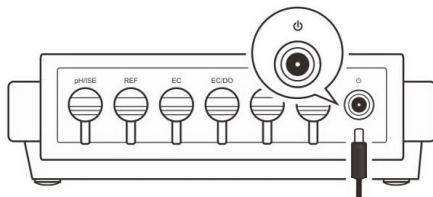

## Connecting the Power Adapter

1. Before plugging in the power adapter, ensure that its voltage matches the local main voltage.
2. Insert the connector to the power socket. The meter is now ready for use.



## Switching the Meter On and Off

- Press and hold the  key to switch on the meter, the display shows the measured values.
- Press and hold the  key for 3 seconds, the meter will switch off.

 To enable the Auto-Power Off feature, please refer to chapter SETUP MENU.





## Setup Menu

The A181 dissolved oxygen meter contains an integrated setup menu that is used to customize the displayed option to meet measurement requirements. The following table describes the functions of the menu items.

MENU	OPTIONS	DESCRIPTION	DEFAULT
Sample ID	0000 to 9999	Set the sample ID to associate readings with the data log.	0000
Calibration Points	1 or 2 points	Set the number of calibration points.	1 point
Barometric Pressure	450 to 850mmHg	Set the barometric pressure coefficient.	760mmHg
	60.0 to 113.3kPa		
Salinity Coefficient	0.0 to 50.0ppt	Set the salinity coefficient of sample.	0.0ppt
Concentration Unit	mg/L	Set the displayed measurement unit.	mg/L
	ppm		
Alarm Limits	Enable	Set the high and low limit values to activate alarm. (Range: 0.00 to 20.00mg/L)	Disable
	Disable		
Calibration Due	Enable	Set the calibration interval to activate alarm (1 to 31 days).	Disable
	Disable		
Temperature Unit	°C	Set the default temperature unit.	°C
	°F		
Stability Criteria	Standard	Set when a measurement is recognized as stable.	Standard
	High-accuracy		
Auto-Read	Enable	When the option is enabled, the meter will automatically sense a stable reading and lock the measurements.	Disable
	Disable		
Auto-Power Off	Enable	When the option is enabled, the meter will automatically switch off if no key is pressed within 3 hours.	Disable
	Disable		
Date and Time	Year-month-day, hour-minutes	Set the current date and time.	
Interval Readings	Off	When the option is enabled, the meter will automatically send the measured data to the computer or printer.	Off
	10 seconds		
	30 seconds		
	60 seconds		
	10 minutes		
	30 minutes		





Password	Enable	Set the password protection for calibration and settings.	Disable
	Disable		
Brightness	Low, Mid, High	Set the brightness level of the backlight.	Mid
Clear Stored Data	Enable	Delete all stored readings in the memory.	Disable
	Disable		
Factory Reset	Enable	Reset the meter to factory default settings.	Disable
	Disable		





**Setting the default option**

1. In the measurement mode, press and hold the  key for 3 seconds to enter the setup menu.
2. Press the  or  key to select the menu item.
3. Press the **Enter** key, the cursor changes to highlight.
4. Press the  or  key to select the desired option.
5. Press the **Enter** key to confirm, the meter returns to the measurement mode. Setting is completed.









**Setting the default parameter**

The meter provides two methods for parameter settings.

- Press the  or  key to modify the value, press the **Enter** key to confirm.
- If the cursor appears below the first digit, press the  or  key to set the value, press the **Enter** key to confirm and move to the next digit. Repeat the steps above until the meter returns to the measurement mode. Setting is completed.

 During the setting process, press the  or  key once, the setting value will increase or decrease gradually. Press and hold the  or  key, the setting value will increase or decrease quickly.

**Setup example - alarm limits**

1. In the measurement mode, press and hold the  key for 3 seconds to enter the setup menu.
2. Press the  or  key select the "Alarm Limits".
3. Press the **Enter** key, the cursor changes to highlight.
4. Press the  key to select the "Enable", press the **Enter** key to confirm.
5. Press the  or  key to set the high alarm value, press the **Enter** key to confirm.
6. Press the  or  key to set the low alarm value, press the **Enter** key to return to the measurement mode.

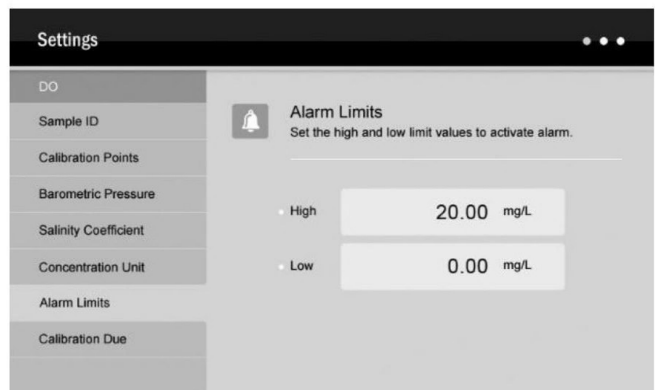
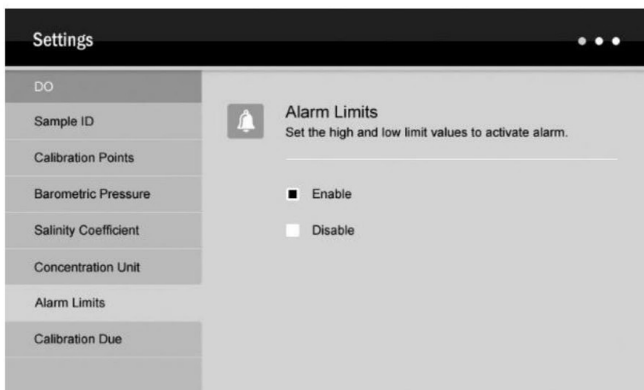

## Stability Criteria

The Stability setting allows the user to set when a measurement is recognized as stable by the meter. When the Standard option is enabled, the Stable icon will quickly appear on the display. When the High-accuracy option is enabled, the icon will take longer to appear, but guarantees high accuracy of the measurement.



## Auto-Read

The Auto-Read feature is used to lock a measurement endpoint. If enabled, the meter will automatically sense a stable reading and lock the measurements. The HOLD icon appears on the display. Press the **Meas** key, the meter resumes measuring.

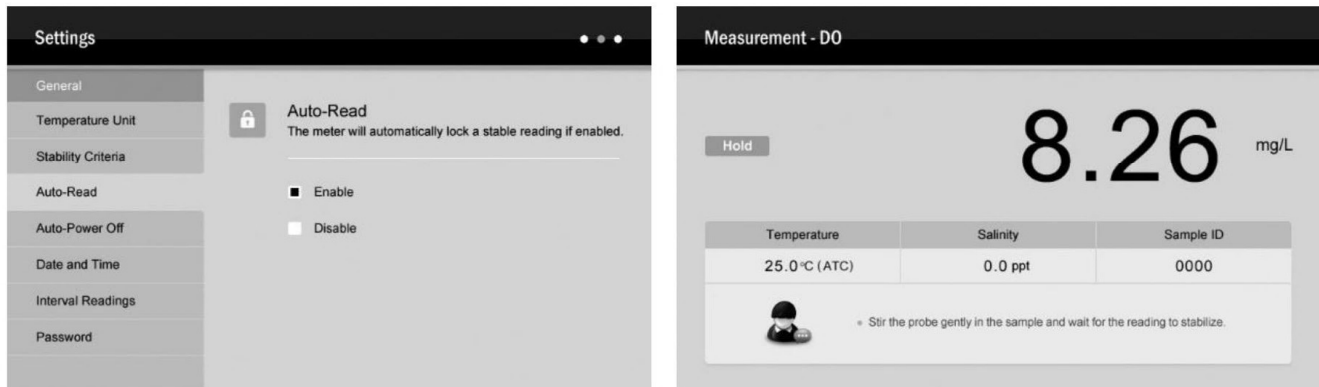

## Interval Readings

The Interval Readings is capable of recording the measurements at the predefined time intervals. If enabled, the meter will continue to send measured data to the printer or computer until the measurement mode is exited. You are able to use the DAS software for receiving the data or viewing the real-time graph. For more details, please refer to chapter COMMUNICATION.

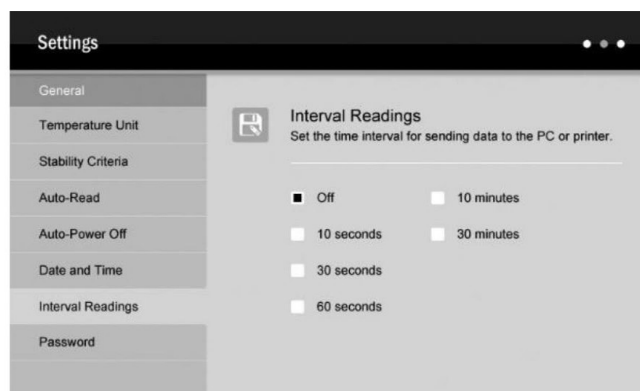



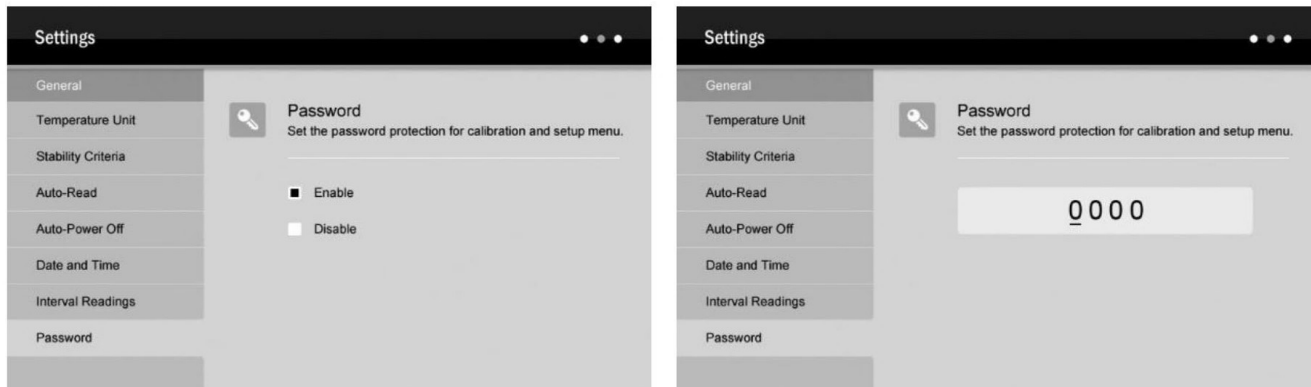

### Password

The password protection is used to prevent the unauthorized calibration and settings. If enabled, the user must enter the 4-digit password to access the calibration or setup menu. If the setting value is 0000, the password protection will be invalid.



### Unlock or Reset the password

Press and hold the  key in the measurement mode, the password input window immediately shows on the display and wait for entering the correct digits. Press the  or  key to input the password, press the **Enter** key to confirm. Once you have successfully entered the setup menu, selecting the "Disable". The password will be removed.

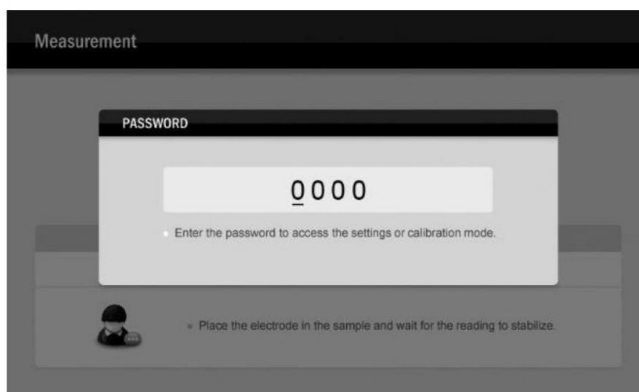

### Factory Reset

The Factory Reset will restore the meter back to factory default settings. If enabled, all of the calibration data and selected options/parameters will be lost or reset, the meter must be recalibrated. During the setting process, when the display shows "Are you sure you want to reset the meter?", press the **Enter** key, the meter will immediately restore the factory settings, press the **ESC** key to cancel.

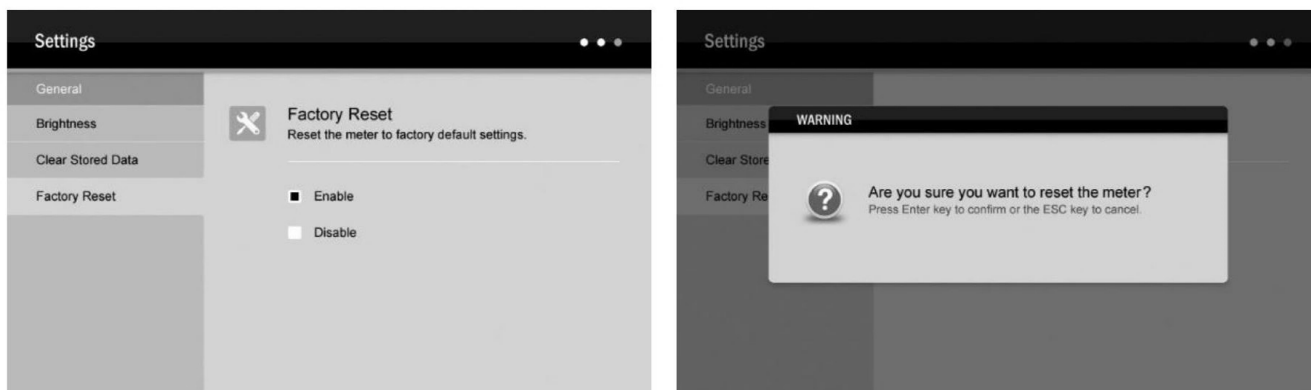

## Prior to Use





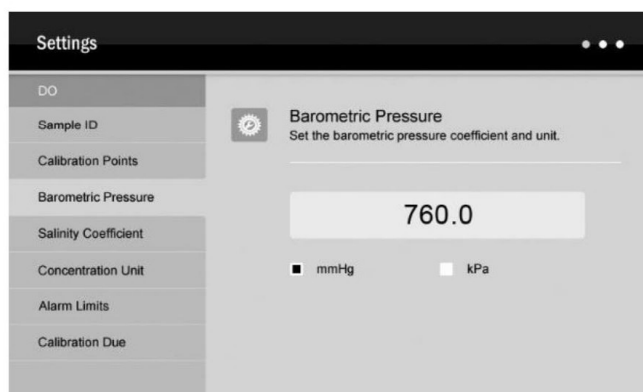

Connect the dissolved oxygen probe to meter (Refer to page 4). Turn on the meter 10 to 15 minutes and wait for the probe to polarize.

## Setting the Barometric Pressure

The following table describes the relationship between altitude and barometric pressure. Prior to the calibration or measurement, you need to set a compatible parameter according to the local altitude.





ALTITUDE (m)	kPa	mmHg	ALTITUDE (m)	kPa	mmHg
0	101.3	760	1600	82.9	622
100	100.1	750	1700	81.9	614
200	98.8	741	1800	80.9	607
300	97.6	732	1900	79.9	599
400	96.4	723	2000	78.9	592
500	95.2	714	2100	77.9	584
600	94.0	705	2200	76.9	577
700	92.8	696	2300	76.0	570
800	91.7	688	2400	75.0	563
900	90.5	679	2500	74.1	556
1000	89.4	671	2600	73.2	549
1100	88.3	662	2700	72.3	542
1200	87.2	654	2800	71.4	536
1300	86.1	646	2900	70.5	529
1400	85.0	638	3000	69.6	522
1500	84.0	630	3100	68.7	515



1. In the measurement mode, press and hold the  key for 3 seconds to enter the setup menu.
2. Press the  or  key to select the "Barometric Pressure", press the **Enter** key to confirm.
3. Press the  or  key to select the desired pressure unit, press the **Enter** key to confirm.
4. Press the  or  key to set the barometric pressure coefficient, press the **Enter** key to return to the measurement mode.

## Setting the Salinity Coefficient

Salt dissolved in water will influence oxygen content of water. If your sample contains high levels of salinity, ensure that setting an applicable salinity coefficient prior to measurement.

1. In the measurement mode, press and hold the  key for 3 seconds to enter the setup menu.
2. Press the  or  key to select the "Salinity Coefficient", press the **Enter** key to confirm.
3. Press the  or  key to set the salinity of sample, press the **Enter** key to return to the measurement mode.

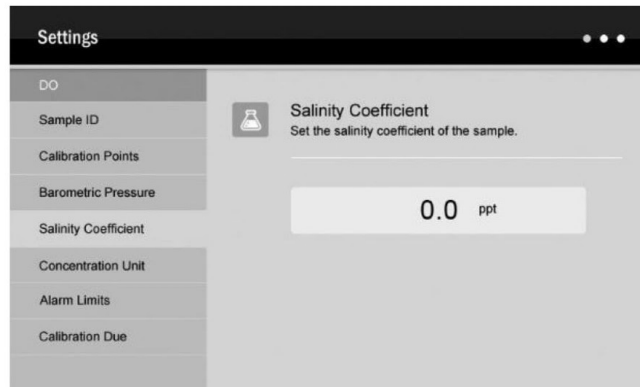

## DO Calibration in % Saturation Mode

The A181 dissolved oxygen meter is able to perform either 1 or 2 points calibration in the dissolved oxygen mode. For single point calibration, we recommend that you perform 100% saturation calibration in the air-saturated water. If the 2 points calibration is selected, the zero oxygen solution needs to be used.

### Single point calibration - 100% saturation

- 1.1 Ensure that the meter is in the "DO (% Saturation)" mode and you have selected 1 point calibration in the setup menu.

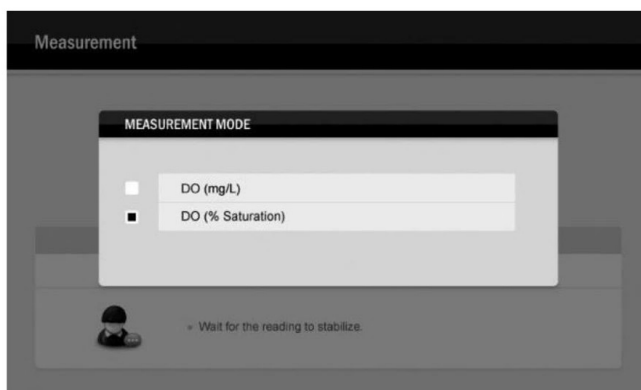

- 1.2 Press the **Cal** key, the meter shows "Calibration Point 100.0%".

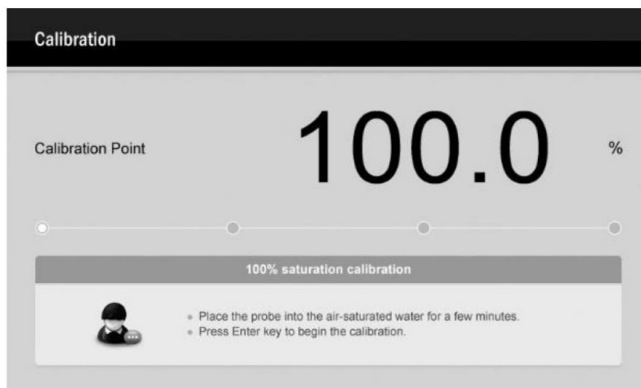

- 1.3 Hold the dissolved oxygen probe in the air at 100% relative humidity or place the probe into the air-saturated water for 15 minutes.  
 1.4 Press the **Enter** key. Wait for the reading to stabilize, the meter will automatically show "Calibration is completed" and return to the measurement mode.

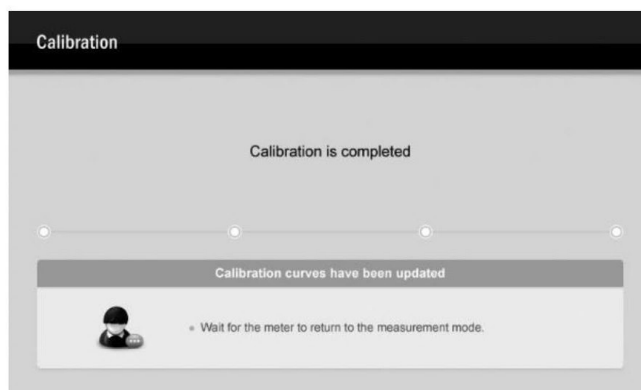
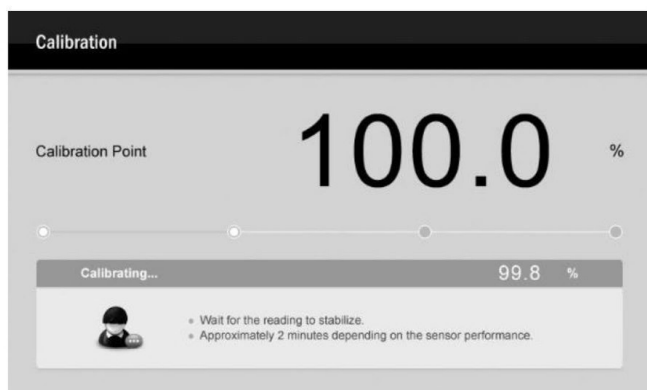

### Single point calibration - zero oxygen

- 2.1 Ensure that the meter is in the % Saturation mode and you have selected 1 point calibration in the setup menu.
- 2.2 Press the **Cal** key, the display shows "Calibration Point 100.0%".
- 2.3 Press the **▲** or **▼** key until the display shows "Calibration Point 0.0%".

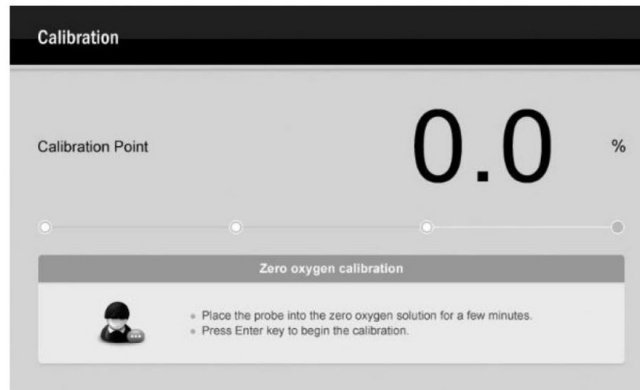

- 2.4 Immerse the dissolved oxygen probe into the zero oxygen solution for at least 10 minutes, press the **Enter** key to begin the calibration. Wait for the reading to stabilize, the meter automatically shows "Calibration is completed" and returns to the measurement mode.

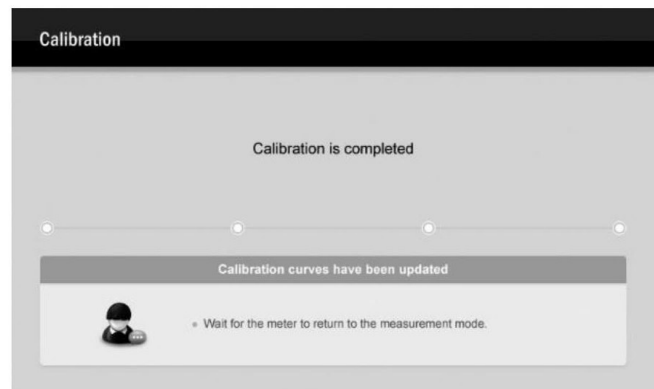
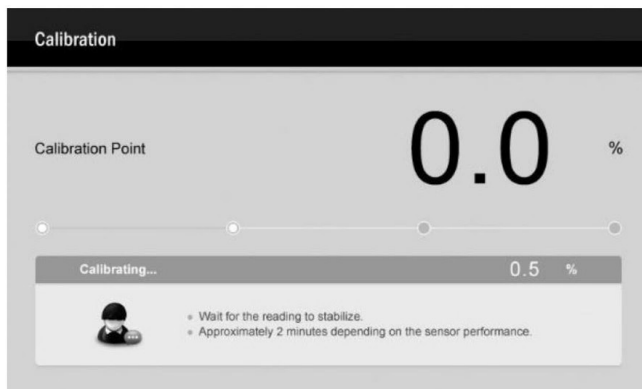

### 2 points calibration

- 3.1 Ensure that the meter is in the % saturation mode and you have selected 2 points calibration in the setup menu.
- 3.2 Repeat the steps above to calibrate the 100% saturation and zero point until the meter returns to the measurement mode.

## DO Calibration in mg/L or ppm Mode

### Single point calibration - air-saturated water

4.1 Ensure that the meter is in the "DO (mg/L)" mode and you have selected 1 point calibration in the setup menu.

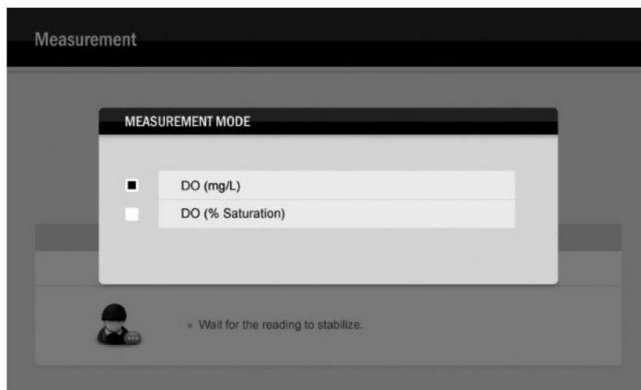

4.2 Press the **Cal** key, the display shows "Calibration Point 8.26mg/L".

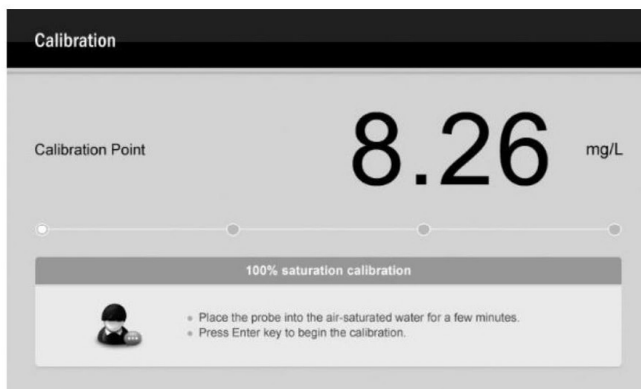

4.3 Immerse the dissolved oxygen probe into the air-saturated water for 15 minutes, press the **Enter** key to begin the calibration. Wait for the reading to stabilize, the meter automatically shows "Calibration is completed" and returns to the measurement mode.

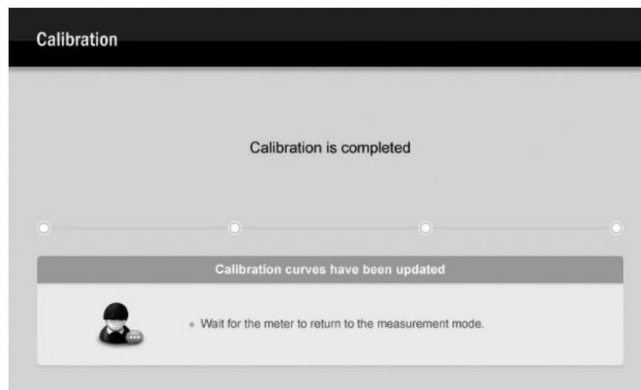
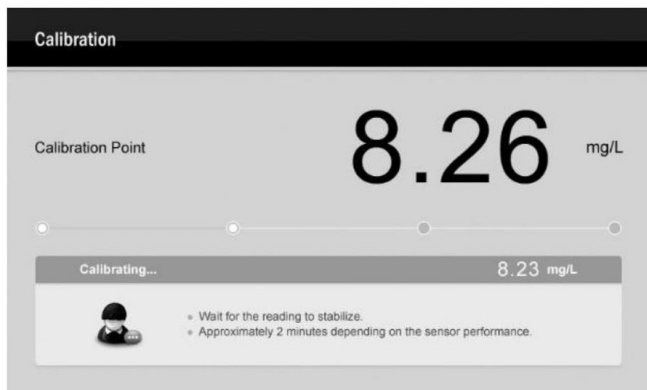

### Single point calibration - zero oxygen

- 5.1 Ensure that the meter is in the "DO (mg/L)" mode and you have selected 1 point calibration in the setup menu.
- 5.2 Press the **Cal** key, the display shows "Calibration Point 8.26mg/L".
- 5.3 Press the **▲** or **▼** key until the display shows "Calibration Point 0.0mg/L".

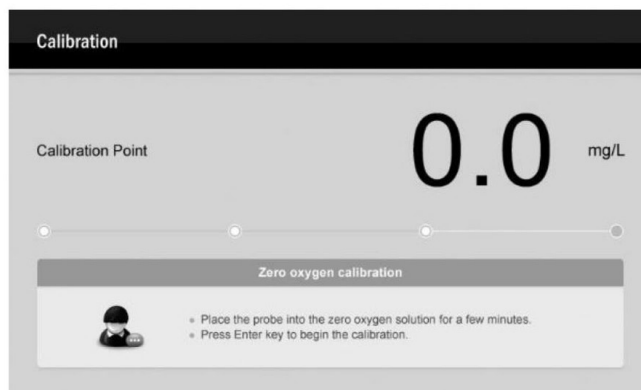

- 5.4 Immerse the dissolved oxygen probe into the zero oxygen solution for at least 10 minutes.
- 5.5 Press the **Enter** key. Wait for the reading to stabilize, the meter automatically shows "Calibration is completed" and returns to the measurement mode.

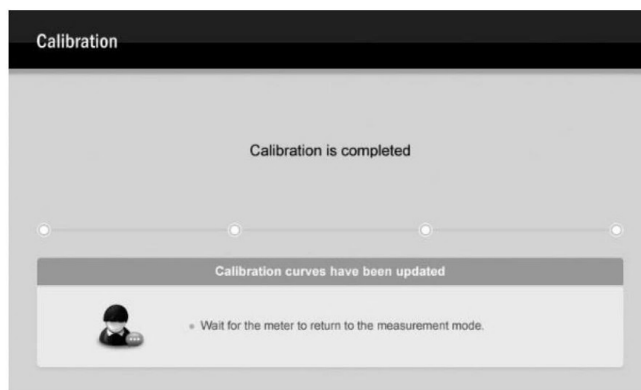
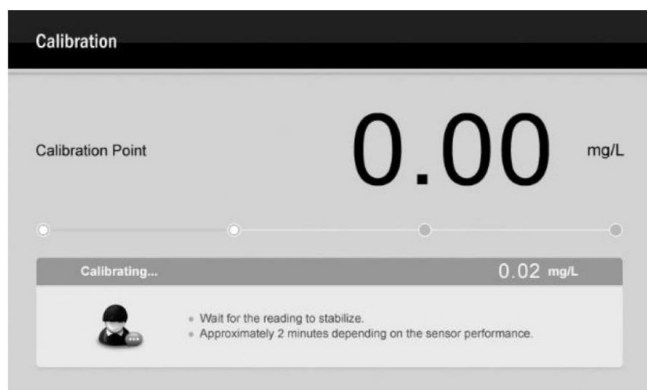

### 2 points calibration

- 6.1 Ensure that the meter is in the "DO (mg/L)" mode and you have selected 2 points calibration in the setup menu.
- 6.2 Repeat the steps above to calibrate the air-saturated water and zero point, the meter will automatically show "Calibration is completed" and return to the measurement mode.

ⓘ If you want to exit the calibration, press the **ESC** key, the meter will immediately return to the measurement mode.

## Temperature Calibration

During the measurement process, if the temperature reading displayed differs from that of an accurate thermometer, the meter needs to be calibrated.

1. Place the dissolved oxygen probe into a solution with a known accurate temperature.
2. Press and hold the **°C** key for 3 seconds to enter the calibration mode.
3. Press the **▲** or **▼** key to set the temperature value.
4. Press the **Enter** key, the meter returns to the measurement mode. Calibrating is completed.

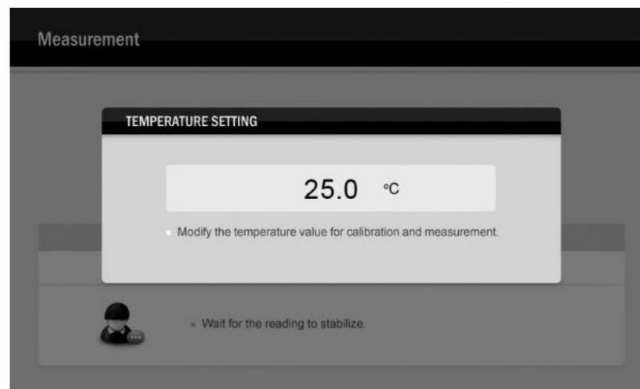

## Calibration Report

The A181 dissolved oxygen meter provides detailed report for the dissolved oxygen calibration.

1. Press the **MR** key in the measurement mode, the meter shows the data log options.
2. Press the **▲** or **▼** key to select the "Calibration Report".
3. Press the **Enter** key, the display shows the updated calibration information.
4. Press the **ESC** key, the meter returns to the measurement mode.

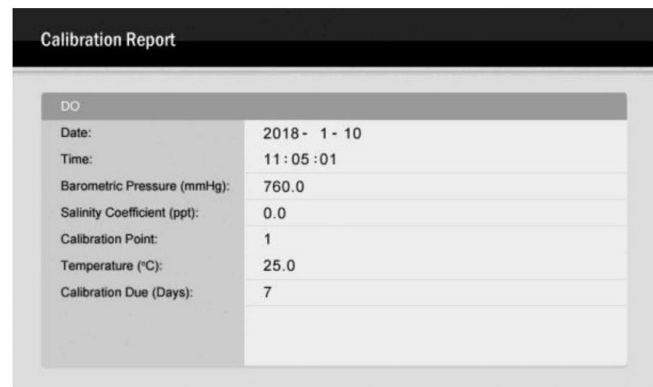
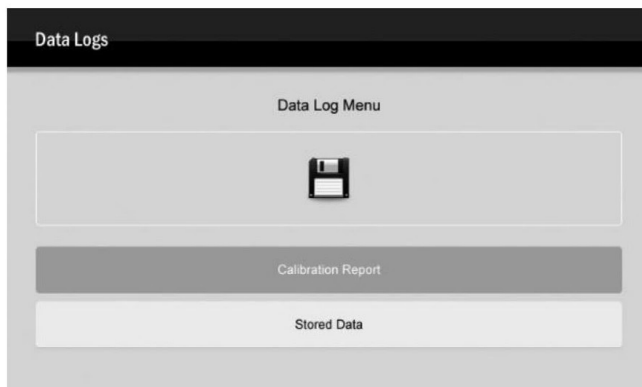



## Dissolved Oxygen Measurement

The A181 meter is suitable for measuring the water, wastewater, brine and other liquids. If the sample is belong to the seawater or other water containing large amounts of salt, please setting the salinity coefficient before measurement. Some gas and steam such as chloride, sulfur dioxide, sulfureted hydrogen, ammonium, carbon dioxide and iodine can permeate the membrane via diffusion. So their existence will influence the measurement of dissolved oxygen. If the sample contains the solvent, grease, sulfide and alga, the membrane on the probe will be blocked, damaged or eroded.

1. Connect the dissolved oxygen probe to meter and wait for 15 minutes to polarize the probe.
2. If necessary, to set the barometric pressure and salinity coefficient in the setup menu (Refer to page 9 and 10).
3. Immerse the probe in the sample solution, make sure the temperature sensor on the probe is fully immersed.
4. Stir the probe gently. Record the measured value when the reading is stable.

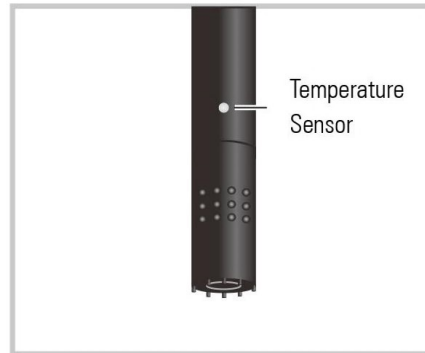

## Storing and Recalling Data from Memory

The A181 dissolved oxygen meter are capable of storing and recalling up to 1000 data sets.

### Storing a measurement result

During the measurement process, press the **MI** key to store the measured value, the meter will show a reminder as follow.

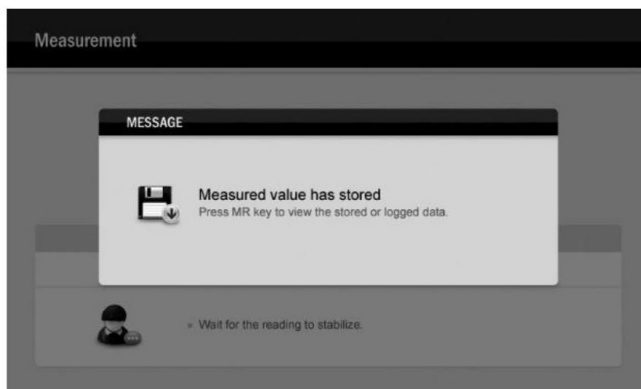

### Recalling from memory

- 1.1 Press the **MR** key in the measurement mode, the meter shows the data log options.
- 1.2 Press the **▲** or **▼** key to select the "Stored Data".

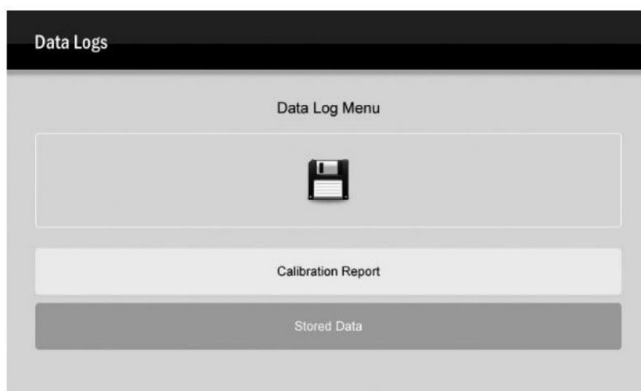

- 1.3 Press the **Enter** key, the display shows the data list.
- 1.4 Press the **ESC** key, the meter returns to the measurement mode.

Date and Time	Sample ID	Reading	Temperature
2018 - 1 - 10 10:29:30	0000	8.26 mg/L	25.0 °C
2018 - 1 - 10 10:30:59	0000	8.23 mg/L	25.0 °C
- - : :			
- - : :			
- - : :			
- - : :			
- - : :			

## Clearing the memory

If the memory is full, the meter will automatically show a reminder and wait for user to delete all stored readings.

**WARNING:** once the data are deleted that can not be recovered.

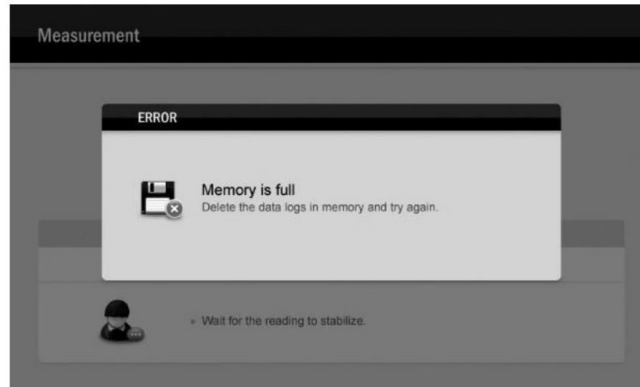

- 2.1 In the measurement mode, press and hold the **⚙** key for 3 seconds to enter the setup menu.
- 2.2 Press the **▲** or **▼** key to select the "Clear Stored Data".
- 2.3 Press the **Enter** key, the cursor change to highlight.
- 2.4 Press the **▲** key to select the "Enable".
- 2.5 Press the **Enter** key, the meter shows a warning "Are you sure you want to delete all date logs ?"
- 2.6 Press the **Enter** key to confirm or the **ESC** key to cancel. The meter returns to the measurement mode.

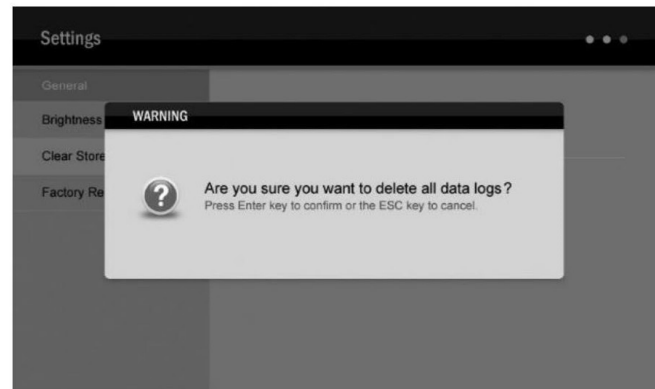
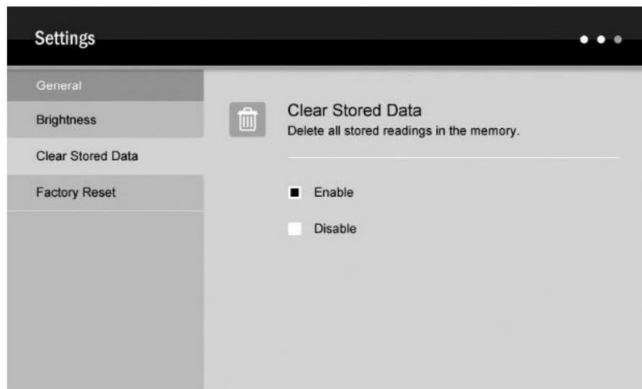

## Communication

Bante Instruments provides a Data Acquisition System that can be used to transfer data, receive the measuring values or import the data to Excel. You are able to download this software from our official website at [http://www.banteinstruments.com](#). Before installation, ensure that Windows 7/8/10 operating system has been installed on your computer.

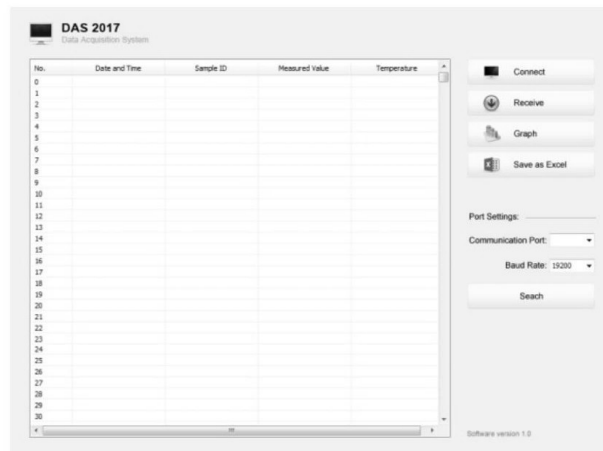

### Receiving data

1. Connect the USB cable and data converter to the meter and computer.
2. Click the DAS\_A\_Series icon on computer, the system will automatically scan an available communication port and show the message box "Found a port on your computer".
3. Click the **OK** button, the application starts.
4. Click the **Connect** button, the screen shows "Port is connected" indicating that the communication between the meter and the computer has been established.
5. Click the **OK** button to confirm.
6. Click the **Receive** button, the stored data automatically transfer to computer.

### Interval recording

This function is used to record the measuring value within the specify time period. The setting method refers to page 6 "Setting the Default Options". Note:

- The first data need 1 minute to be shown on screen.
- Do not press any key on meter during the Interval Recording mode, it will cause the communication interruption.

### Graph mode

This function helps user to view variations of the measured value continuously. Click the **Graph** button, the screen immediately shows the curve graph. Click the **X** button to quit.

### Create the excel file

When the data transfer is completed, click the **Save as Excel** button, the measured values in the data sheet will automatically convert to Excel file. **WARNING:** Once the software is closed, all received data will be lost and can not be recovered.

## Electrode Care and Maintenance

- Always keep the membrane of the dissolved oxygen probe is wet or moist.
- If you do not use the probe for long periods, please screw off membrane cap and rinse the cathode, anode and membrane with deionized water, then soak up residual water on them with filter paper. Install the probe again.

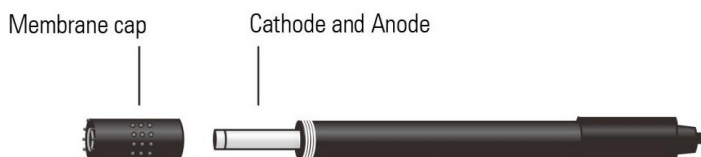

## Specifications

Dissolved Oxygen	Model	A181
	Range	0.00~20.00mg/L
	Accuracy	±0.2mg/L
	Resolution	0.01mg/L
% Saturation of Oxygen	Range	0.0~200.0%
	Accuracy	±2.0%
	Resolution	0.1%
General	Calibration Points	1 or 2 points
	Temperature Compensation	0~50°C, 32~122°F, Automatic
	Barometric Pressure Correction	450~850mmHg, 60.0~113.3kPa
	Salinity Correction	0.0~50.0g/L
	Memory	Stores up to 1000 data sets
	Output	USB Communication Interface
	Connector	6-pin
	Power Requirements	DC12V/2A, using AC adapters, 220VAC/50Hz
	Dimensions	240 (L) × 220 (W) × 80 (H)mm
	Weight	1.7kg

## Addendum: Preparation of the Zero Oxygen Solution

Dissolve 500mg of sodium sulfate ( $\text{Na}_2\text{SO}_3$ ) reagent and a small amount of cobalt(II) chloride hexahydrate ( $\text{CoCl}_2 \cdot 6\text{H}_2\text{O}$ ) in the 250mL distilled water, mix the solution until reagent is completely dissolved.

## Hazardous Substance Statement

Instruments is committed to the reduction and eventual elimination of all hazardous substances in both the manufacturing process and finished products we supply. We have an active manufacturing and procurement program to minimize and eliminate the use of harmful heavy metals such as cadmium, lead, mercury and the like. New technologies and design parameters are also promoting these efforts and we expect to have little or no such materials in our product in the coming years. We welcome our customer suggestions on how to speed up these efforts.



## Warranty

The warranty period for meter is one year from the date of shipment. Above warranty does not cover the sensor and calibration solutions. Out of warranty products will be repaired on a charged basis. The warranty on your meter shall not apply to defects resulting from:

- Improper or inadequate maintenance by customer.
- Unauthorized modification or misuse.
- Operation outside of the environment specifications of the products.

For more information, please contact the nearest authorized distributor.