

Operation Manual

For Hand Held Refractometer

Parts Diagram:

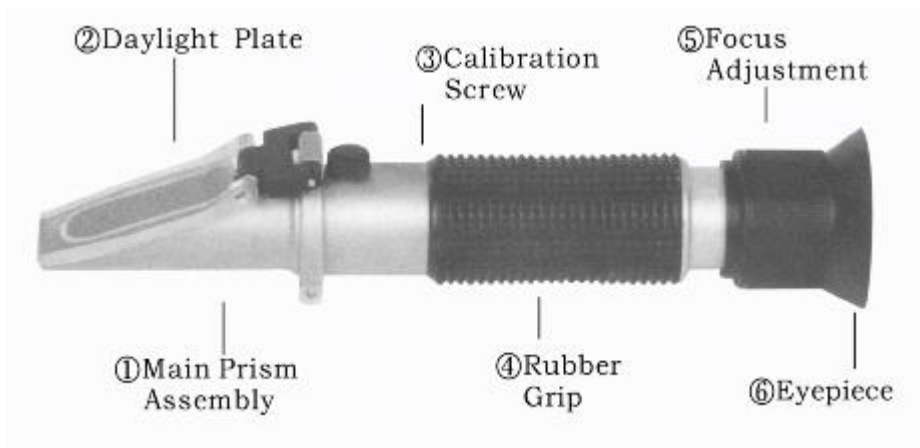

Operation Steps:

Step1.

Open daylight plate, and place 2-3 drops of distilled water on the main prism. Close the daylight plate so the water spreads across the entire surface of the prism without air bubbles or dry spots. Allow the sample to temperature adjust on the prism for approximately 30 seconds before going to step 2.

This allows the sample to adjust to the ambient temperature of the refractometer.



Step2.

Hold daylight plate in the direction of a light source and look into the eyepiece. If you will see a circular field with graduation down the entrance, you may have to focus the eyepiece to clearly see the graduation. The upper portion of the field should be blue, while the lower portion should be white. (The pictures shown here and shown in step3&step4 are only as reference. The right specific scale is listed the products.)

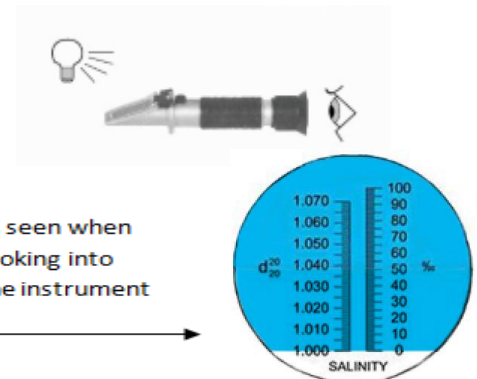

Step3.

Look into the eyepiece and turn the calibration screw till the boundary between the upper blue field and the lower white field meet exactly on the zero scale, such as shown in the image. That is the end of the calibration process. Make sure the ambient room temperature is correct for the solution you are using (20°C/68°F). When working temperature of the room or environment (not the sample) changes by more than 5°F, we recommend recalibrating to maintain accuracy. If the instrument is equipped with Automatic Temperature Compensation system, the ambient working temperature of the room must be 20°C/68°F whenever the instrument is recalibrated. Once calibrated, shifts in ambient temperature within the acceptable range (10°C-30°C) should not affect accuracy.

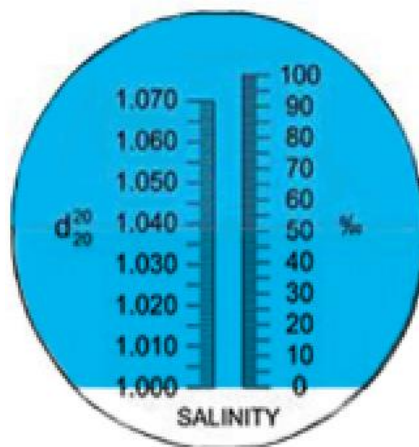

Calibrate to "0" scale

Step4.

Now place a few drops of the sample to be tested onto the main prism, close the daylight plate and check reading. Take the reading where the boundary line of blue and white separating the graduated scale. The scale will provide a direct reading of the concentration.

Each model of scale different, but the operation method is totally the same.

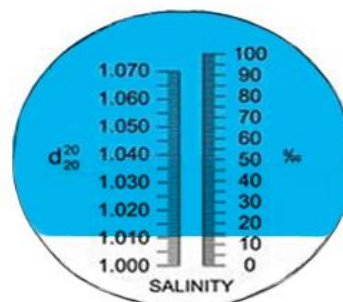

Reading of Sample

Warning-Maintenance

1. Accurate measurement depends on careful calibration. The prism and sample must be at the same temperature for accurate results.
2. Don't expose the instrument to damp working conditions, and don't immerse the instrument in water. If the instrument becomes foggy, water has entered the body. Call a qualified service technician or contact your dealer.
3. Don't measure abrasive or corrosive chemicals with these instruments. They can damage the prism's coating.
4. Clean the instrument after measurement using a soft damp cloth. Failure to clean the prism on a regular basis will lead to inaccurate results and damage to the prism's coating.
5. This is an optical instrument. It needs careful handling and storage. Failure to do so can result in damage to the optical components and its basis structure. With care, this instrument will last years of reliable service.