

INSTRUCTIONS

FA/JA ELECTRONIC BALANCE
OPERATION

6) In the gravity mode:

Push the “tare” button ,the balance comes back to the weighing mode ,and shows the weight value.

Push the “unit” button ,to select different measuring mode.

Notice: when the balance display gravity, only the tare, unit, print button can be used.

V、 gravity measuring error

1) **When the balance display ERR under gravity measuring, you can make the balance back to the weighing mode by pushing the tare button, at the same time, the balance shows the weight.**

Notice: after gravity error, just the TARE and OFF button can be used.

VI、 count button:

1) Used as counting under weighing mode

2) Used as calculating and remembering function

VII、 the instrument has the function of mode remembering

9.Random Accessories

1. 200g(and100g)calibration weights	1 piece
2. Wire with both-side plug	1 piece
3. Weights tweezers	1 piece
4. Handkerchief	1 piece
5. Operation manual	1 piece
6. Certificate	1 piece
7. Brus	1 piece
8. Nipper	1 piece

CONTENT

1. Outline	(01)
2. Main technical Specifications	(02)
3. Drawings for Balance Installation	(04)
4. Operating	(06)
A. Preparation	(06)
B. Operation	(06)
C. Start	(06)
D. RNG Weighing	(07)
E. UNT Unit Change	(08)
F. INT Integrating Time Adjustment	(08)
G. ASD Sensitivity Adjustment	(08)
H. PRT Output Mode Setting	(09)
I. COU Count Function	(09)
J. Weighing, Taring, Add Objects, Read Devitions	(10)
5. Maintenance and Troubleshooting	(11)
6. Dats InterfaCe	(12)
7. Serial Single (RS232C)	(13)
8. Density balance operation	(14)
9. Random Accessories	(15)

1. Outline

Thank you for busying the type FA/JA series electronic balance from our company. For correct and safe fixing and operation, as well as full function apply, we suggest that you should read the users' manual before using it Thanks.

The balance is multifunctional electronic balance using MCS-54series SCM This balance has gram, cant, ounce for users to select (cant and ounce for export) besides having automatic calibration, integral time adjustment and stability adjustment functions This balance has RS232C data serial duplexing port to connect with microcomputer and serial port punter This balance is used for fast exact weight measuring widely in enterprise, university, graduate school lab as an ideal lab instrument.

Finally, after reading the manual, please keep it carefully for referring.

8. Density Balance Operation

I Measuring mode selection: press the "UNT" button immovably, the balance will show the following in turn

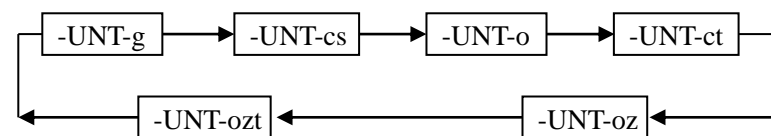

-UNT-cs: measuring the liquid gravity mode

-UNT-o : measuring the solid gravity mode

-UNT-g, -UNT-ct, -UNT-oz, -UNT-ozt: All the weighing mode, show the model upper right at the same time

g : gram; ct: carat; oz: ounce; ozt: 0.911 ounce;

cs: liquid gravity; o: Solid gravity

II measuring the liquid gravity

- 1) put the thermometer on the wall of the beaker
- 2) put the beaker on the center of the bedplate
- 3) Put the "tare" button to zero the balance ,put the liquid component (platinum ,plumb) wire on the fix support
- 4) Inject the sample in the beaker(immerge the plumb completely),push the "count" button ,the balance shows "-----".the balance will show the gravity value directly after the sensor data is stable

III、 solid gravity measuring

- 1) put the thermometer on the wall of the beaker
- 2) put the beaker on the center of the bedplate
- 3) Inject the water in the beaker, make sure the sample can be immersed in the water completely
- 4) Put the basket on the fix support, make sure it does not touch the beaker and thermometer
- 5) Tare the balance, put the sample on the scale on the support ,push the "count" button ,the balance shows "_____" ,when the instrument shows the value again, put the sample in the basket slowly ,then the balance shows "_____" again ,then ,the instrument shows the gravity value directly3

6.Date Interface

Date interface adopts the standard 9-core RS-232C sDcket. The date interface is provided with RS232C universal two - way serial interface, which can be connected to the microprocessor and various printers.No.Standard Parallel Output.The pin and the corresponding signanls are as follows:

PIN	SIGNAL	ILLUSTATE
1	SI	input signal
2	GND	
3	SO	serial output signal(baud rate is 1200)
4	GND	

7.Serial Single (RS232C)

The connection method between the scale and computer serial port is as follows:

Computer(9pins)	Scale(9pins)
2	----- 2
3	----- 3
5	----- 5

- 1) The baud rate of the serial port of scale is 1200.
- 2) The date format is 10digits, one start digit is(0) ,8 digits are date positions (ASCII Code,low digits in the front),1 stop digit.
- 3) No odd-even check
- 4) The date will be output continuously without any special reading commands A detailed output frame is as follows:

1	2	3	4	5	6	7	8	9	10	11	12	13	14	15	16
Type	Space	*/Space	+/-	Date	Date	Date	Dot	Date	Date	Date	Date	Unit1	Unit2	CRLF	

2.Main technical Specifications

Model	FA1004b	FA1104b	FA1604b	FA2004b	FA2204b
Accuracy Degree	Ⓛ	Ⓛ	Ⓛ	Ⓛ	Ⓛ
Weighing Range(g)	100	110	160	200	220
ReadingAccuracy(mg)	0.1	0.1	0.1	0.1	0.1
Taring Range(g)	0~100	0~110	0~160	0~200	0~220
Repeatability Standard Deviation(g)	±0.0002	±0.0002	±0.0002	±0.0002	±0.0002
Linear Error(g)	±0.0005	±0.0005	±0.0005	±0.0005	±0.0005
Stable Time (Typical)(s)	≤6	≤6	≤8	≤8	≤8
Integrating Time (Adjustable)(s)	2/4/8	2/4/8	2.5/5/10	2.5/5/10	2.5/5/10
Pan Dia.(mm)	Φ 80				
Overall Dimensions (mm)	360×217×345				
Net Weight(kg)	6.8				
Power Supply	9.0V-12.0A、---1000MA				
Power Consumption (V.A)	15				
Auto-Cal Weight Range(g)	100	100	160	200	220
Warm-upTime (mis)	180	180	180	180	180

Model	JA1003b	JA2003b	JA3003b	JA5003b	JA10003
Accuracy Degree	Ⅱ	Ⅱ	Ⅱ	Ⅰ	Ⅰ
Weighing Range(g)	100	200	300	500	1000
Reading Accuracy (mg)	1	1	1	1	1
Taring Range(g)	0~100	0~200	0~300	0~500	0~1000
Repeatability Standard Deviation(g)	±0.001	±0.001	±0.001	±0.001	±0.001
Linear Error(g)	±0.002	±0.002	±0.002	±0.002	±0.002
Stable Time (Typical)(s)	≤6	≤6	≤6	≤6	≤6
Integrating Time (Adjustable)(s)	2/4/8	2/4/8	2/4/8	2/4/8	2/4/8
Pan Dia.(mm)	Φ 80			Φ 110	
Overall Dimensions (mm)	360×217×345				
Net Weight(kg)	6.8				
Power Supply	9.0V-12.0A、=1000MA				
Power Consumption (V.A)	15				
Auto-Cal Weight Range(g)	100	200	200	500	1000
Warm-up Time (mis)	60	60	60	180	180

Note: The balance is turned on when the power is on. The panel switches activate display only. The power plug should be removed if the balance is not used for a long time. If it is used daily, the power needn't be turned off. The only thing needs to be done is to turn off the display. It is not necessary to warm up due to the power on, so it can be used at any time. ("A long time" means more than 5 days.)

SN	TROUBLE	CAUSE	REMEDY
6	Display remains at a certain digit or indicates nonsense symbol	<ul style="list-style-type: none"> Instant interference Wring line voltage 	<ul style="list-style-type: none"> Turn on the balance once again or replug the power cord Change to normal line voltage
7	The stable mark "0" on the left of the display doesn't go out	<ul style="list-style-type: none"> A higher balance sensitivity undesirable environment such as strong air flow or vibration 	<ul style="list-style-type: none"> Set to lower sensitivity Improve the environment
8	Remain at Waiting Status	<ul style="list-style-type: none"> The balance position is not correct, e.g. With strong air flow, vibration or great fluctuation of room temp. The selected sensitivity is too high 	Improve the environment ASD-3
9	Cal Err Displays	<ul style="list-style-type: none"> There is an object on the pan before calibration not clear before calibration Depress CAL before the 	<ul style="list-style-type: none"> Take away the object, clear and recalibrate Clear and recalibrate
10	Err-1 Err-2 Display	<ul style="list-style-type: none"> Instant interference Something wrong with the balance 	<ul style="list-style-type: none"> Turn on the balance once again Send it to the service center
11	The weighing unit on the right doesn't display	<ul style="list-style-type: none"> not calibrated The calibrated number in the internal memory of the balance has been erased 	Calibrate the balance
12	Cou-Err Display	<ul style="list-style-type: none"> No Constant be set before operating counting function Overload when setting constant Underload when setting constant 	Set average number before operating counting function

UNLOAD

Loose the screw of the bottom cover, reveal the hook. Put the balance on a working table with a hole. Level and calibrate the balance. An object can be weighed with the hook.

5. Maintenance and troubleshooting

MATNTENANCE OF THE BALANCE

The balance should be used carefully. Clean the pan and the case frequently with soft cloth and toothpaste. Don't wipe the balance with strong agent.

TROUBLESHOOTING

SN	TROUBLE	CAUSE	REMEDY
1	No light on Display	<ul style="list-style-type: none"> Power is not on Dispsy switch is not on Instant interrence 	<ul style="list-style-type: none"> Check and turn it on again Depress ON button Switch on again and replug power
2	Disply the upper hstf only	<ul style="list-style-type: none"> Overload The calibration in the intemal memores may ba damaged The pan is not installed correctly 	<ul style="list-style-type: none"> Reduce the load immediately Recalibrate according to the above procedures. About 8 seconds after the standard weight has been put on, the calibrated result may be displayed. A certain stable time is necessary. Take out the pan and reinstall it.
3	Display the lower half Only——	<ul style="list-style-type: none"> without pan, too light he pun is not installed correctly 	<ul style="list-style-type: none"> Reinstall the pan
4	The weighing result is not stable (date changed swiftly)	<ul style="list-style-type: none"> due to air flow the working table it net stable the integrating time is too short Roam tetnpealtsre flucttsates 	<ul style="list-style-type: none"> Check the windproof cover tu see if it is closed. Change to a longer integrating time
5	The retult is not correct	<ul style="list-style-type: none"> not zeroing before weighing Use the balance without calibration or the cal weight is not accurate The line vollage is too low or net correct 	<ul style="list-style-type: none"> Depress TAR button Reclibrate Change to the correct voltage

3. Drawings for Balance Installation

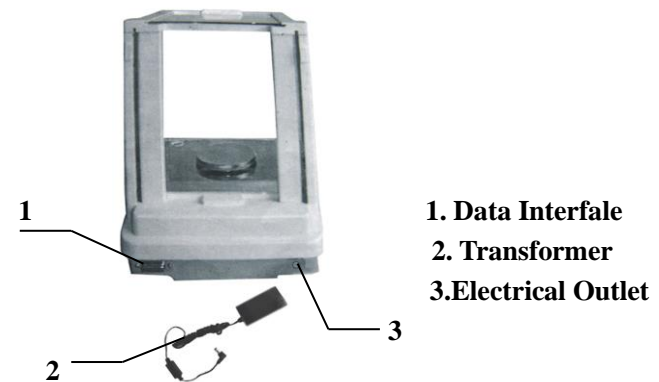
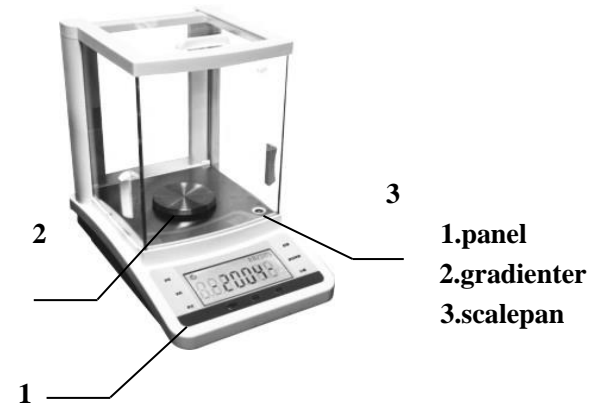



Single Measuring Range

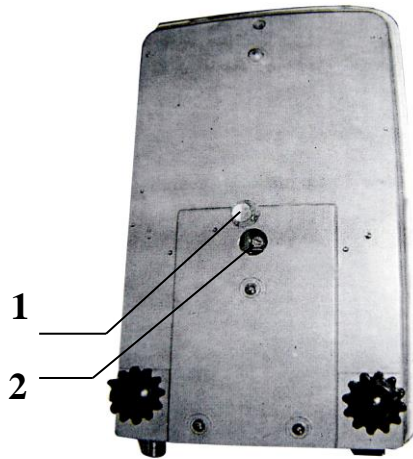

1.Cover Honrd

2..Pothook

J . Weighing ,Taring ,Add Objects ,Read Devitions

WEIGHING

After the selection of the above modes(all the modes can be used for weighing after the power is off ,due to the memorv function of the balance),depress TAR,zero will display.Put the object to be weight on the pan.When the number is stable, i.e.“0”on the left of the displaygoes out,the number display goes out,the number displayed will be the weight of the object.

TARING

Put the container on the pan, the weight will display.Depress TAR,zero displays. That is taring. Put the objects to be weighed into the container, the value displayed is the net weight of the object to be weighed

ACCUMULATIVE WETGHTNG

Pat the objects be weighed on the pan one by one with taring method and tare and clear for each one.Take away all the objects to be weighed , the absolute value display in the total weight of the objects to be weighed.

ADD OBJECTS

Set the mode of INT-0 and put the container on the pan , then tare. Add the objects to be weighed (liquid or loose objects) into the container one by one the continuous reading value can be obtained quickly. when the added objects reach the required“0”on the left of the display goes out and the number display is the weighing value required by the user. When adding the mixed objects.the net weight of each object can be measured by taring method.

PEAD DEVIATIONS

Put the reference weight(or rample) on the pan and tare . then take off the reference weight the negative value of the weight display.Put the object to be weighed on the pan.The corre sponding plus or minus deviution will display, comparing the weighed object with the reference weight

H . PRT Output Modde setting

Depress PRT and hold there will be four modes displayed circularly for user to select at will..

PRT-O is the mode of indefinite time output ; slightly depress PRT once ,the weighing result will be.out on the output interface once.

Attention: At this time you should depress the button slightly and quickly, otherwise, the next output mode will be displayed

PRT-1 output once every half a minute

PRT-2 output once every minute

PRT-3 output once every two minutes

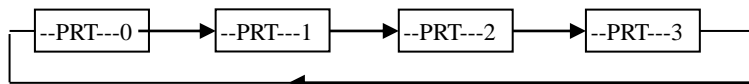

The setting of PRT is the same as RNG

I. COU Count Function

The balance has a function of counting. The average number are 5,10,25and 50,total of four .The Setting of Range of Average Numbers

Only depress COU and hold ,the display will be circulating continuously as the following.

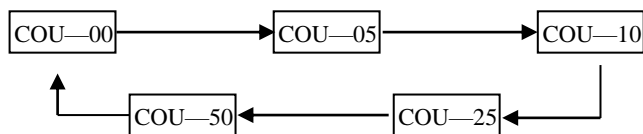

It means the average value of (5,10,25,50)objects respectively

if a normal weighing function is required ,release when COU-00 display, and waiting status“.....” will be indicated ,at last0.000g weighing status will be indicated .If the average value of five is required, release when COU-5 displays, then put5 objectson the pan Depress CAL once again. “.....”waiting status displays ,and about several seconds later,5 will be displayed. Take away the objects

to be weighed ,zero displays. At that time the counting of the same objects to be weighed can be done (Attention :the weight of the objects to be weighed must not be greater than the maximum weighing rang of the balance). If you average over 10,25 even SO objects ,then the accuracy of counting will be higher Depress TAR,“0”will be indicated in the display and counting can be done at that time.

4. Operating

A. Preparation

• Unpack the box and remove all packings . Take out buffer sponge in the wind proof cover and install pans.

• Put the balance on a stable working table free from vibration, sunshine and air flow.

• Ambient temperature:

20°C ± 5°C for the first class balance with a fluctuation of temperature not greater than 1°C/h;

20°C ± 7.5°C for the second class balance with a fluctuation of temperature not greater than 5°C/h;

• Relative humidity:50%-75% for the first class lance, 50%-80% for the second class balance.

• Working 9.0V-12.0A, 1000MA voltage:

B. Operation

• Check the level meter before operation,if the bubble is not in the center, adjust the level legs to make the bubble in the center..

• The balance adopts soft touch buttons , so it can be controlled with multikey boards .It is easy to operate .Function change and selection can be realized simply by depressing the corresponding buttons.

C. Start

• Select an appropriate line voltage and set the voltage switch to the corresponding position.

• Turn the power on and the balance is ready to run (but the display doesn't work),normally one hour after power is on , the display can be operated.

Function of the keyboard:

“ON” DISPLAY ON

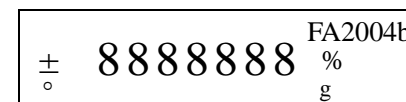

Depress slightly the button “ON” the display will be lighted..

Check the function of the display ,about 2 seconds later ,the model of the balance will be displayed.

For example:

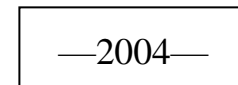

then the weighing mode.

0.0000g or 0.000g

0.0000g

0.0000g

“OFF” DISPLAY OFF

Depress slightly the button“OFF” ,the display will go out. If the balance will not be used for a long time ,the power plug should be taken off.

“TAR” Clear and Tare

Put the container on the pan,the weight of the container should be displayed:

+18.9001g

Depress “TAR” button,the display will go out and the display will be all zeroes. Taring ia completed:

0.0000g

When the container is removed, a negative value of the container weight will be displayed.

-18.9001g

Depress“TAR”again, the display will be all zeroes,i.e.the balance clears.

0.0000g

D.Balance calibration

the balance should be calibrated after a long period of storage, movement, change of environment or in order to obtain precise measurement.

Preparation for the balance calibration:

(a).Take away all the objects to be weighed on the pan. Depress slightly TAR for clear the balance.

(b).Depress slightly CAL.CAI-200 will be on the flash-display. Therefore, put the prepared 200g standard weight on the pan ,the flash-display will stop.

After several seconds, 200.000g will be displayed. Remove the calibration weight,the display should indicate 0.000g. if not clear once again and repeat the above procedures. (Attention:More than two times of calibration are mcommended in order to get accurate result.)

CAL-200 FA2004b

Notice: 1,the TAR button can stop the calibration at any time
2,depress the TAR button until displaying 0.0000g before calibrating

E.UNT Unit Change

If the accuracy of the reading needs to be 0.1mg release when the display is mg-60; and the appears waiting state...,the weighing state will be shown at last.

Depress ERY button and hold until the display is shown as the following figure circulating continuously.

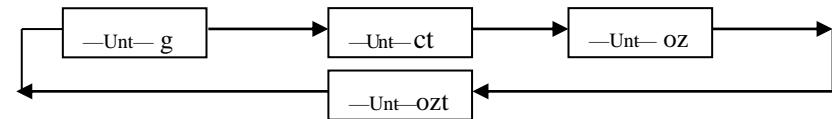

“g” means the value is expressed in gram .“ct” means the value is expressed in metric carat. “ozt” means the value is expressed in. The unit will be set same as RNG.

F. INT Integrating Time Adjustment

Four modes of integrating time can be selected circularly as shown in the figure

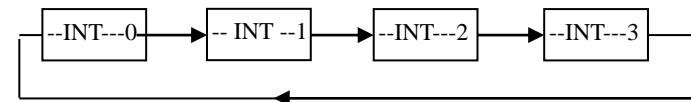

The corresponding integrating time is as follows:

INT-0 fast, INT-1 shorter, INT-2 short, INT-3 longer

The selection of the integrating time will be the same as RNG

G. ASD Sensitivity Adjustment

Same as INT interrating time adjustment button: there are four circulating modes provided for sensitivity adjustment.

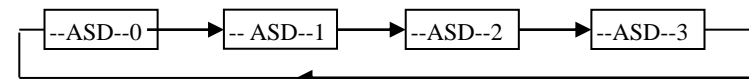

ASD—0 the highest ASD—1 high ASD—2 higher ASD—3 low

ASD-0 is used for test run and not to be used by the users.

The selection of sensitivity is the same as RNG.

Here is a list of ASD used with INT for user’ s reference only.

The fastest weighing: INT-1 ASD-3

Normal: INT-3 ASD-2

With undesirable environment INT-3 ASD-3