

Packing List

No.	Item	Type	QTY
1	Card Centrifuge	TD2-24	1
2	Rotor		1
3	Card holder	In the rotor	24
4	Operations manual		1
5	Power Line		1

Foreword

Thank you for purchasing our products: Card Centrifuge, this manual for users contains function and operation of the instrument. In order to use the instrument properly, please read this manual carefully before using the instrument.

Opening Check

Please check the instrument and Appendix with the packing list when you first open the instrument packing case. If you find there is something wrong with the instrument and the Appendix, do contact with the Technical Service

Contents

1. Introduction	1
1.1 Delivery package	1
1.2 Structure Description	2
1.3 Installing the device	3
2. Technical data	4
3. Safety precautions	5
4. Operation guide	6
4.1 Control elements	6
4.2 Rotor insertion and removal.....	6
4.3 Loading the rotor	6
4.4 Centrifugation with a preset time	6
4.5 Centrifugation speed and time setting	7
4.6 Open the centrifuge in the event of a power failure ..	7
5. Maintenance and cleaning	8
6. Troubleshooting	8
Annex 1 Wiring Diagram for centrifuge	9
Packing list.....	10

Annex 1 Wiring Diagram for Centrifuge

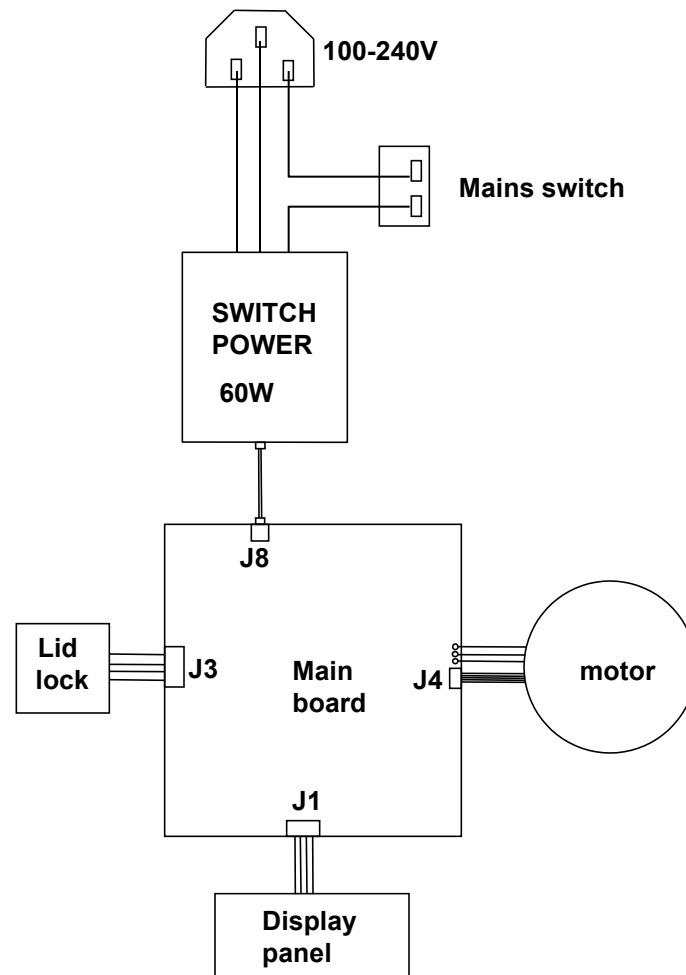

5 Maintenance and cleaning



The rotor and the outside of centrifuge should be cleaned regularly with a moist cloth. Disconnect the centrifuge from the mains supply, remove the rotor and clean it separately. Only neutral agents may be used for cleaning.



Please check the rotor and especially the rotor bores regularly for deposits or damage, then reinsert the rotor.

6 Troubleshooting

Error	Cause	Solution
No display	No main power connection. Power failure.	Plug in mains cable on both sides. Check the mains fuse
Lid can't be opened.	Power failure. Rotor is still spinning. Lid lock failure.	Emergency lid release(see sec.4.6). Stop centrifuge run. Contact Technical Service.
Centrifuge shakes during acceleration	Rotor not loaded symmetrically.	Stop centrifuge run and load centrifuge symmetrically.
ERR01	Open lock failure	Contact Technical Service.
ERR02	Close lock failure	Contact Technical Service.
ERR08	Out of balance	Verify : The number of cards is an even number. The cards are distributed symmetrically.

1 Introduction

This centrifuge designed for gel card .Before starting up this centrifuge for the first time, please read the rest of this operations manual.

1.1 Delivery package

Card Centrifuge	1 pcs
Rotor	1 pcs
Card rack	24 pcs
Operations manual	1 pcs

1.2 Structure Description

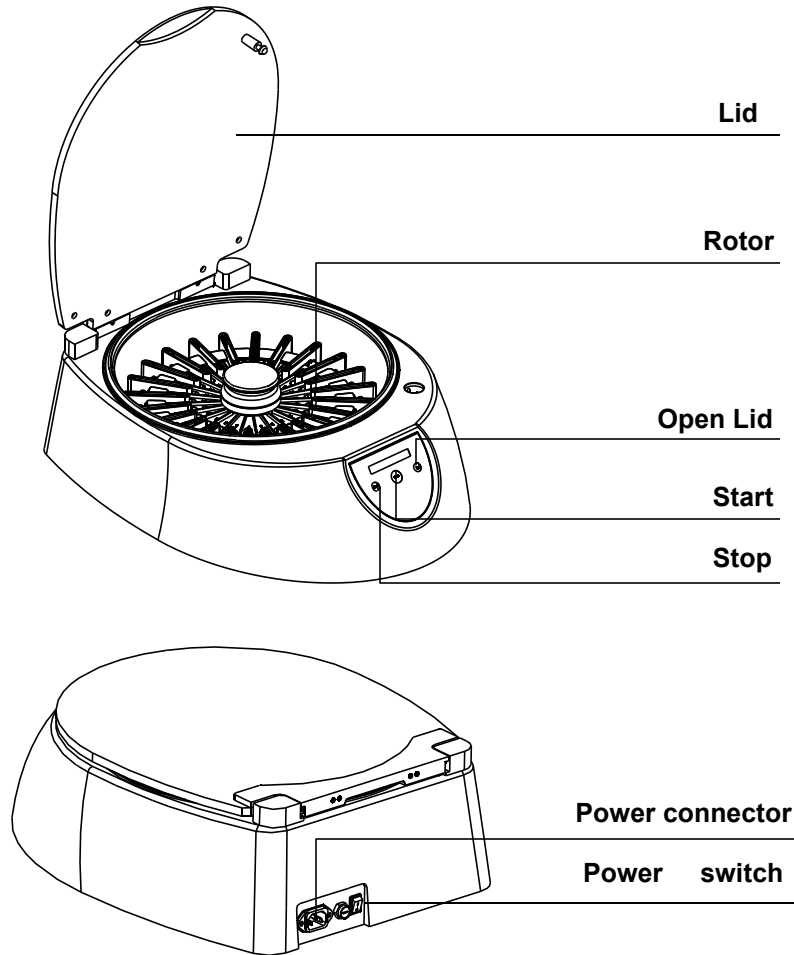

4.5 Centrifugation speed and time setting

4.5.1 Speed and time setting

First of all, press and hold the “Lid” key, then press “stop” key; the machine comes to the setting interface, at this time the speed and time can be set. The cursor turns out under the speed figure. In the display, the sign “■” is first speed and first time. Press “stop” to move the cursor to switch from the first speed and time to the second speed and time. The sign “■” means the second speed and time.

900 rpm	02:00	First speed and time
1500 rpm	05:00	Second speed and time

At the setting interface, in order to change speed and time, press “stop” to move into the value which is needed to set. Press “start” to increase the set value, and press “Lid” to reduce the set value. After 3sec, the cursor disappears, and the system will accept the new setting values. The speed can be set from 500rpm to 1500rpm, and the time can be set from 1min to 20min.

4.5.2 Switching to the rcf display

Pressing “STOP” key for 2 seconds continuously, the display switches from rpm to rcf. Also pressing “STOP” key continuously again, the display switches from rcf to rpm.

4.6 Open the centrifuge in the event of a power failure

when centrifuge running, the electricity supply cut unexpectedly, and the lid can not be open, please operate as following. Turn off the switch, pull out the power plug, wait till the rotor stop totally. Lift front right parts of the instrument, find the lock rod on the bottom, (see picture Fig-a), turn the rod to left side, the lid lock will be open after a sound of “pa...”, (see picture Fig-b).

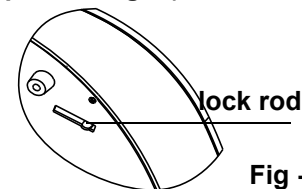

Fig - a

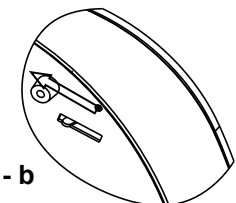

Fig - b

4. Operation guide

4.1 Control elements

START-----for start centrifugation

STOP----- for stop centrifugation

LID-----to open the lid

4.2 Rotor insertion and removal

Fit the rotor onto the crossed linker of the motor, the crossed linker will connect the rotor by magnetic force .

Pull away the rotor from the motor.

Before each start, check that the rotor is firmly tightened !

4.3 Loading the rotor

Place the Gel cards in such a way , put the Gel cards in the card holder as shown by Fig – c. And rotor must always be loaded symmetrically

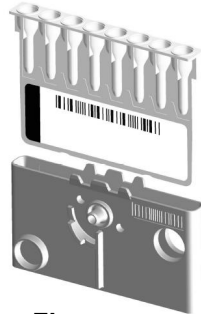

Fig - c

4.4 Centrifugation with a preset time

4.4.1 Turn on the mains switch, pressing “Lid” to open the lid, load the rotor symmetrically. Close the centrifuge lid, make sure the lid is locked by pressing on it by your hand. (The lid will be locked totally after you hear a sound of “da”.)

4.4.2 Pressing “START” to start the run . Pressing the “STOP” to end the run prematurely. The remaining run time appears in the display.

After the run , the lid lock of centrifuge opens automatically, And buzzer alarms “du du du” .

1.3 Installing the device

1.3.1 Place the centrifuge onto a level , horizontal surface.

Open the lid, take out the foam for delivery .

1.3.2 Insert the column connector of the power line to power connector of the device ,and insert another connector of the power line to mains power supply.

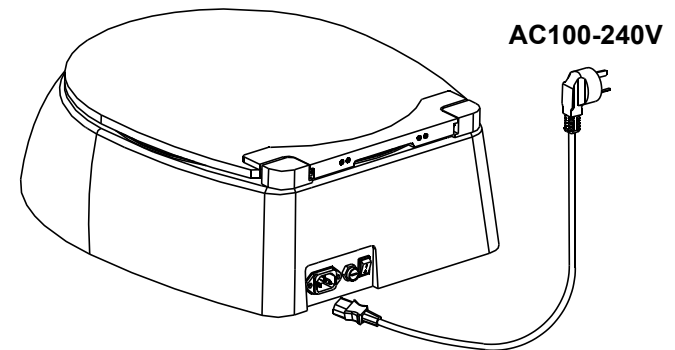

1.3.3 A safety distance of 30 cm should be observed around the centrifuge during operation. No objects which could cause additional damage in the event of a centrifuge crash should be positioned in this space.

1.3.4 Power on the main switch. The centrifuge is ready to operate when the display becomes visible. Place the rotor onto the rotor axle .

2 Technical data

Model	TD2-24
Power supply	100-240 V 50-60Hz
Power	85 W
Centrifuge speed	500 ~ 1500 rpm (33.0 ~ 294.0 g)
Centrifuge time	1 ~ 20 min
Load capacity	24 gel cards
Ambient temperature	15 ° C ~ 40 ° C
Dimensions W×D×H	410mm×530mm×180mm
Weight with rotor	11.5 kg

3 Safety precautions



If the centrifuge makes unusual noises when started, the rotor is not fastened correctly. Switch the device off immediately by pressing "STOP" key.



Do not use damaged rotors !



Do not move the centrifuge during the run !

3.1 Place the cards

3.1.1 Damaged cards can not be centrifuged.

3.1.2 Must load the test cards symmetrically.

3.2 Maintain of rotor

3.2.1 Even slight scratches and tears of the rotor can lead to serious internal material damage

3.2.2 Avoid damage caused by aggressive chemicals, including among others: strong and weak alkali, strong acids.

3.2.3 In the event of contamination caused by aggressive agents, The rotor must be cleaned immediately using a neutral cleaning liquid.

Operation Manual

V 1.0

TD2-24

Card Centrifuge

