

DH-L Type High Precision Constant
Temperature Incubator
User Manual

Thank you for choosing to use our DH-L series electric constant temperature incubator. This series of products are widely used in the cultivation of bacteria/microorganisms in industrial and mining enterprises, food processing, agriculture, biochemistry, biology, and pharmaceutical industries. Your trust is our support and we will serve you wholeheartedly.

Remind you

This manual describes in detail the product features, usage methods, precautions, etc. For your better understanding, convenient and safe use of this product, we recommend that you carefully read this manual before use before use.

After you receive the product, please confirm whether it is the same as the one you ordered, and then confirm whether the appearance of the product is intact and the random accessories matches the packing configuration list.

If the product model you received is inconsistent with your booking or the appearance is damaged or there are not enough accessories, please contact our sales staff in time.

Contents

1. Safety warning before operate	1
2. Product main features	2
3. Technical Parameters	3
4. Meter operate and display instructions	4
5. Wiring Diagram	7
6. General failures and trouble shooting method	8
7. Product Quality Guarantee	9

1.Safety warning before operate



Must prohibit items

The following items could cause serious injury or death

1. Read the product instruction manual before using this product.
2. Do not put volatile、flammable and explosive stuff in the machine, otherwise could cause explosion or fire.
3. Do not place the device in a place exposed to rain, moisture, or splashing, as this may result in electrical leakage, short circuit, or electric shock.
4. Non-professional technicians must not disassemble, repair or modify the equipment, otherwise it may cause fire or electric shock to personnel due to improper operation.
5. Do not damage the power plug or the power cord. If it is damaged, the power cord must be replaced. Otherwise, it may cause fire or electric shock.



Must conform items

The following items may cause personal injury, equipment damage and related property damage.

1. This equipment should install on the firm ground, otherwise could cause staff injury
2. because of drop down of the equipment.
3. Please use the special power supply that indicated one the nameplate. This equipment must install on the ground, otherwise could cause electric shock and fire because of electric leakage.
4. Do not touch the power plug with wet hands, otherwise there is a risk of electric shock
5. Before any repair or maintenance is carried out, the power must be disconnected to prevent electric shock or injury.
6. Please wear gloves when repair and maintain the equipment in case of injury.
7. Do not to damage the power cord or use the non - specified power cord, do not connect the power cord in the middle section and use long soft wire, otherwise it may lead to electric shock or fire.
8. Do not remove the power plug during the operation, do not pull the power cord by pulling the power cord.
9. If you find that the equipment is running abnormally, unplug the power plug immediately and stop the equipment.



Necessary Considerations.

The following items could cause staff injury or equipment

1. Adjust the feet so that the equipment is installed horizontally, and all four feet should be close to the support surface. There must be no vacant or false.
2. Use a separate power outlet fitted with a grounding wire. Tight the power plug when in use.
3. Put off the power plug, before removing the equipment,
4. Carefully touch the inner wall of the door, which may be hot.
5. Non professional technical staff could not disassemble the machine privately, Professional staff should repair and replace parts.
6. The internal parameters must be set by the specific management person to prevent the function of the controller program from being disturbed by don't know setting operation.
7. The installation location of the equipment must be longer than 20 cm from the wall and from the object.
8. Open or close the door gently. Rudely opening or closing the door can easily cause damage to the equipment.
9. The surface of the equipment must not be exposed to volatile chemicals such as gasoline or thinner.
10. Keep the inside and outside of the box clean, often cleaning debris and smudges

2. Product main features

1. There is a fan for the breeze circulation in the product working room, and a large area of mica electric film heating at the bottom, so that the temperature distribution of work chamber uniformly .
2. Large-screen LCD display, multiple sets of data, one screen display, intelligent PID temperature control system, with PT100 high-precision sensor, high temperature control accuracy.
3. Double door structure, the inner door is made of high quality tempered glass to facilitate the observation of samples, the outer door is made of magnetic strips, opening and closing is convenient, and the sealing is good. It has the function of opening and closing the door.
4. Standard light, germicidal light, breeze circulation fan, 485 communication interface.
5. Independent temperature limiter: imported mechanical temperature limiter, set the work room limit temperature, to provide double safety protection for the product.

3. Technical Parameters

Model		DH45L	DH65L	DH125L	DH210L
Cycle Mode		Breeze circulation			
Function	Temp. Range	RT+5-65°C			
	Temp. Resolution Ratio	0.1°C			
	Temp. Motion	±0.5°C			
	Temp. Uniformity	±0.8°C			
Structure	Inner Chamber	Mirror stainless steel			
	Outer Shell	Cold rolling steel electrostatic spraying exterior			
	Insulation layer	Polyurethane			
	Heater	Mica electrothermal film			
	Power Rating	0.35kW	0.45kW	0.6kW	0.7kW
	Exhaust hole	φ28mm top(with function of test hole)			
Controller	Temp. control mode	PID Intelligent			
	Temp. setting mode	Touch button setting			
	Temp. display mode	Measuring temperature: LCD upper row; Setting temperature: the lower row			
	Timer	0-9999 min (with timing wait function)			
	Operation function	Fixed temperature operation, timing function, auto stop.			
	Additional function	LED Floodlight, Sensor deviation correction, temperature overshoot self-tuning, power-off parameter memory			
	Sensor	PT100			
Safety device		Mechanical independent temperature limiter,			

		over temperature sound-light alarm			
Specification	Inner Chamber size (W*L*H)(mm)	350*350 *350	400*350 *450	500*450 *550	600*580 *600
	Exterior size (W*L*H)(mm)	525*480 *620	575*480 *720	675*580 *820	775*710 *870
	Packing size (W*L*H)(mm)	605*572 *775	655*572 *875	755*672 *975	855*802 *1025
	Volume	45L	65L	125L	210L
	Shelf number	7	9	13	14
	Load per rack	15kg			
	Shelf space	35mm			
	Supply(50/60HZ) Current rating	AC220V/ 1.1A	AC220V/ 1.1A	AC220V/ 2.3A	AC220V/ 2.7A
	NW/GW (kg)	27/30	32/35	45/49	58/63
Accessory	Shelf	2			
	Shelf frame	4			
optional accessories		Shelf, USB interface, printer, recorder, External Communication, remote control, wireless SMS alarm			

4.Meter operate and display instructions

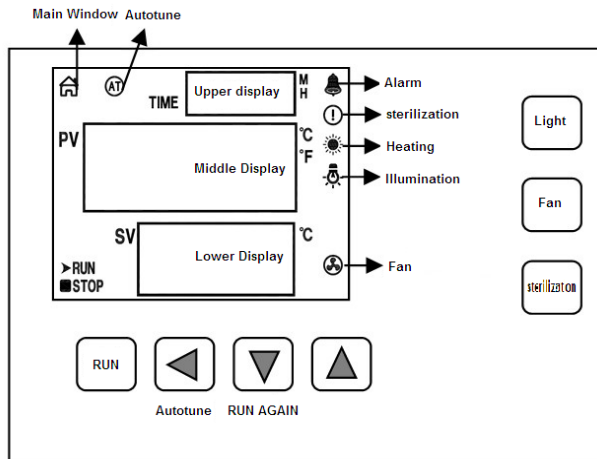

Indicator definition:

1. "Main window" indicator: Light is on in the normal working state (non-set state), otherwise it is off.
2. "Auto-tuning" indicator: This indicator flashes when running the auto-tuning program, otherwise it goes off.
3. "RUN" indicator: This indicator off when the timer over, otherwise it stays on.
4. "STOP" indicator: This indicator lights up when the timer expires, otherwise it goes off.
5. "Alarm" indicator: This indicator is on when there is a deviation alarm on temperature or when the temperature measurement is abnormal. When there is a deviation alarm under temperature, this indicator flashes. Under normal operation, this indicator goes
6. "Heating" indicator: light up when heating output, otherwise lights off.
7. "Light" indicator: light up when turn on, otherwise lights off.
8. "Fan" indicator: Fan work when turn on, otherwise it is off.
9. "Sterilization" indicator: Lights up when turn on, otherwise it is off.

Operation and usage

1. The controller is powered on. The middle display area shows [index number and meter type]. The lower display area shows [version number], about 2 seconds into the normal display state.

2. Temperature and time reference and setting

1) If there is no timing function:

Click [Set] button to enter the temperature setting state, the middle display area displays prompt "SP", the lower display area shows the temperature setting value, which can be

modified by [Inc], [Decrease] and [Shift] keys go to the desired setting value; then click the [SET] button to exit this setting state and the modified setting value is automatically saved.

2) If there is timing function

Click [Set] button to enter the temperature setting state, the middle display area displays the prompt "SP", the lower display area shows the temperature setting value, the modification method is the same as above; then click the [Set] button, enter the time setting in the status display area. The prompt "ST" is displayed, the upper display area shows the time setting value. Then click the [Set] button to exit the setting status. The modified setting value is automatically saved.

When the time is set to "0", it means there is no timing function and the meter runs continuously. When the set time is not "0", the upper display area shows the running time. When the timer starts, the "time unit" flashes, the time is up, the operation ends, the upper display area shows "End", and the buzzer intermittently sounds EST Seconds (see the internal parameter table-2) and stop. After the timer runs out, long press[Down] for 3 seconds to restart the run.

3. Abnormal temperature measurement alarm

If "----" is displayed in the middle display area, it means that the temperature sensor is faulty or the temperature exceeds the measurement range or the controller itself is faulty, the controller automatically disconnects the heating output, the buzzer sounds continuously, and the alarm light is on. Check the temperature sensor and wiring carefully..

4. When the upper deviation exceeds the over-temperature alarm, the buzzer sounds, the warning light is on, and the heating output is turned off; when the lower deviation exceeds the over-temperature alarm, the buzzer sounds, and the warning light flashes; if the temperature value is changed due to over-temperature alarm. The alarm light is on, but the buzzer does not sound.

5. When the buzzer sounds, you can press any key to stop.

6. [Light] key: Click this key to switch the lighting and the corresponding indicator lights up or goes out.

7. [Fan] key: Click this key to switch the fan and the corresponding indicator lights up or goes out.

8. [Sterilization] key: Long press this key for 6 seconds to start sterilization, click this key to turn off the sterilization, and the corresponding indicator lights up or goes out.

9. [Shift] key: Click this button in the setting state to shift the set value by flickering; in the normal display state, long press this key 6 seconds to enter the temperature auto-tuning selection state.

10. **【Dec】** key: Click this key to decrease the set value in the setting state. Long press this key to decrease the set value continuously. In the normal display state, press this key when the timer runs out. Long press 3 seconds can restart the run.

11. **【Inc】**key: Click this key to increase the set value in the setting state. Long press this key to increase the set value continuously.

System self-tuning

In the normal display state, long press the [SHIFT] button for 6 seconds to enter the

system self-tuning selection state, the middle display area shows the self-tuning prompt "AT", the lower display area shows "0", you can click [Inc] or [Dec] key to select "1" or "0" to display. When "1" is displayed, click [Set] key, the meter enters the system self-tuning state, and the auto-tuning indicator flashes. After the auto-tuning is completed, the indicator The light stops flashing and the controller will get a better set of PID parameters. The parameter values are saved automatically. In the process of system self-tuning, long press the [Shift] key for 6 seconds to stop the self-tuning process. If there is an upper deviation over temperature alarm during the system self-tuning, the warning light will not be on and the buzzer will not be called, but the heating alarm relay will be automatically disconnected. The [Set] key is invalid during system auto-tuning.

Reference and setting of temperature internal parameters

In the normal display state, long press the [Set] button for 3 seconds, the middle display area displays the password prompt "Lc", the lower display area shows the password value, and is modified by [Inc], [Dec] and [Shift] The required password value. Then click the [Set] button. If the password value is incorrect, the controller automatically returns to the normal display state. If the password value is correct, enter the internal parameter setting state, and then click the [Set] button to modify each parameter in turn. Press and hold the [SET] button for 3 seconds to exit this status. The parameter values are automatically saved. See the table below for details:

Internal parameter table -1

Parameter	Parameter name	Parameter function description	(Range) Factory Value
Lc	Password	The parameter value can be viewed and modified when "Lc=3".	0
ALH	Upper deviation Over temperature alarm	When "Temperature measurement > Temperature set value + HAL", there is an upper deviation over temperature alarm.	(0~100.0°C) 5.0
ALL	Lower deviation Over temperature alarm	When "Temperature measured value < temperature set value-ALL", there is a lower deviation over temperature alarm. Note: When "ALL=0", the lower	(0~100.0°C) 0
P	Proportional band	Time proportional effect adjustment.	(0.1~300.0°C) 10.0
I	Integration time	Integral function adjustment.	(1 ~ 2000
d	Differential time	Differential regulation.	(0 ~ 1000
T	Control period	Heating control cycle.	(1 ~ 30Second)
Pb	Measurement temperature deviation correction	It is commonly used to correct errors that occur during low temperature measurements. Pb = actual temperature value -	(-50.0~50.0°C) 0

PL	Measuring temperature slope correction	It is often used to correct errors that occur during high temperature measurements. PL = 1000 * (actual temperature value - meter measurement) / meter measurement	(-999~999) 0
Addr	Communication address	This machine communication address	(1~32) 1
Loc	Set lock	0: Can modify the temperature or time setting value; 1: It is forbidden to modify the temperature or time setting value.	(0~1) 0

Internal parameter table -2

Parameter	Parameter name	Parameter function description	Factory value
Lc	Password	When "Lc=9", the parameter values can be viewed and modified.	0
ndA	Temperature Alarm mode	0: Only temperature deviation overtemperature alarm; 1: At the same time, there are temperature and lower deviation over temperature alarm.	(0~1) 0
ndc	Temperature control mode	0: Fuzzy PID control; 1: Bit control	(0~1) 0
dE1	Bit control Upper deviation	When the "temperature measurement > temperature setting value + dE1", turn off the heating output.	(0~100.0°C) 0
dE2	Bit control Lower deviation	When the "temperature measurement value is less than the temperature setting value D 2", the heating output is turned on. Description: this parameter is effective	(0~100.0°C) 0
ndT	Timing mode	0: No timing function; 1: Constant temperature timing; 2: Starting up timing	(0~2) 1
Hn	Constant temperature timing	0: Minute time; 1: Hour time	(0~1) 0
SPd	Constant temperature deviation	When the "temperature measurement value is more than or equal to the set point of temperature", it is considered to enter the constant temperature state.	(0.1~100.0°C) 0.5
SPT	Constant temperature Prompting time	When entering the constant temperature state, the buzzer prompts the time. Note: when "SPT=9999", it represents a permanent prompt.	(0~9999sec) 0

EST	Timed end Prompting time	When the timing is over, the buzzer prompts the time. Note: when "EST=9999", it represents a permanent prompt.	(0~9999sec) 60
EH	Whether to continue the constant temperature control at the end of the timing	0: Turn off the heating output after timing; 1: The constant temperature control is continued after the timing is finished.	(0~1) 0
ndo		Reserved, invalid.	
oPn	Gate control function	0: Close Gate control function; 1:Open Gate control function	(0~1) 0
nP	Maximum power output	Maximum power percentage of heating output	(0~100%) 100
Co	Turn off heating output deviation	When the "temperature measurement value \geq the temperature setting value +Co", turn off the heating output. Description: this parameter is valid only when PID is controlled.	(0 ~ 100.0°C) 50.0
SPL		Reserved, invalid.	
SPH	Maximum temperature Set value	The maximum value of the set value of the temperature.	(0 ~ 100.0°C) 100.0

Note 1: in order to avoid misjudgement, you should choose the function of closing the door and power off for a system that does not need to open doors or power down

Internal parameter table -3

Parameter	Parameter name	Parameter function description	Factory value
Lc	Password	When“Lc=27”, the parameter values can be viewed and modified.	0
Fc	Unit of temperature	0: degree Celsius; 1: Fahrenheit degree	(0~1) 0

Internal parameter table -4

Parameter	Parameter name	Parameter function description	Factory value
Lc	Password	When“Lc=567”, the parameter values can be viewed and modified.	0
rST	Unit of temperature	0: Cancellation of factory value; 1: Confirm the resumption of the factory value	(0~1) 0

Digital Temperature Limiter Panel Instructions

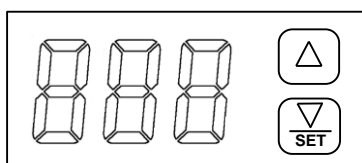

Button function

- 1) 【▲】: “INC” button. In the setting state, click this button to increase the set value. If you keep pressing this button, the value will increase continuously.
- 2)【▼/SET】: “DEC” button. In the setting state, click this button to reduce the set value. If you keep pressing this button, the value will reduce continuously. It has the setting function when modifying internal parameters.

1. Operation and using

1-1. When the controller is switched on, display window shows the version number for 2 seconds, then it starts running.

1-2. Alarm temperature setting

Under the normal state, window displays temperature alarm set value. Click the “INC” or “DEC” button, the set value starts flashing, at this point, the required temperature alarm setting can be modified through the “INC” and “DEC” button. About 2 seconds after stopping operation, the controller will return to the normal state, the set value will be saved automatically.

1-3. View temperature measurement

In the normal state, press the “INC” and “DEC” button for about 3 seconds, The right decimal point will light up. At this point, the window displays the measured temperature value. Click the “INC” or “DEC” button again, the controller will return to the normal state.

1-4. Over temperature alarm

In the normal state, when the temperature measurement exceeds the alarm temperature setting value, the window alternately displays " - A - " and alarm setting value, the controller will cut off the output automatically, the buzzer beeps.

1-5. Abnormal temperature measurement alarm

If the window show the prompt “---”, it indicates that the temperature sensor has faults or temperature exceeds the measuring range or the controller itself is faulty, the controller will cut off the output automatically, the buzzer will sounds continuously.

Please check the temperature sensor and its wiring carefully.

1-6. When the buzzer sounds, press any button to mute.

2. View and set internal parameters

In the normal state, press the “INC” and “DEC” button for about 6 seconds, the window alternately displays "Lc" and password value, the required password value can be modified only by the “INC” button. Then click the “DEC” button, the controller will enter the internal parameters setting state. Press the “DEC” button for 3 seconds, it will return to the normal state, the set value will be saved automatically.

Parameter table

Prompt	Name	Function description	(Setting range) Factory value
Lc	Password key	When “Lc=3”, enter the next parameters.	0
Pb	Temperature deviation correction	It is usually used to correct errors in low temperature measurement. $Pb = \text{Actual value} - PV$	(-50~50°C) 0
PL	Temperature slope correction	It is usually used to correct errors in high temperature measurement. $PK = 1000 \times (\text{Actual value} - PV) \div PV$	(-199~199) 0
SPH	Max set value	The maximum temperature set point value.	(0~400) 400

5. Wiring Diagram

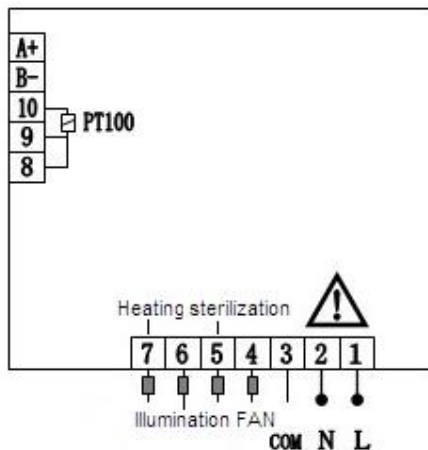

6. General fault and troubleshooting

Failure phenomenon	Fault analysis	Troubleshooting
Temperature control instrument display 0000 or----	<ol style="list-style-type: none"> 1.The sensor is broken 2.Sensor connection shedding 3.The controller is broken 	<ol style="list-style-type: none"> 1.Replace sensor 2.Check the connection and connect firmly 3.Replace controller
The temperature has been rising uncontrolled	<ol style="list-style-type: none"> 1.Controller wiring board is broken 	<ol style="list-style-type: none"> 1.Replace controller wiring board
The circulating fan does not turn or has abnormal sound	<ol style="list-style-type: none"> 1.The motor is broken 2.Controller wiring board is broken 3.Motor fan blade damage 	<ol style="list-style-type: none"> 1.Replace motor 2.Replace controller wiring board 3.Replace Motor fan blade
Setting temperature is greater than measuring temperature. The temperature does not rise	<p>The heater is broken</p> <p>Temperature limiting device setting temperature too low</p> <p>The instrument is heated with output but not heated</p>	<ol style="list-style-type: none"> 1.Replace the heater 2.Properly adjust the temperature of the temperature limiter
Overshoot of temperature	Incorrect setting of instrument related parameters	<ol style="list-style-type: none"> 1.Check the instructions for readjustment
The effect of sample culture is inconsistent	<ol style="list-style-type: none"> 1.The sample is placed too much in the studio to lead to poor uniformity 	<ol style="list-style-type: none"> 1.The sample of no more than 80% of the volume.

7.Product quality guarantee

To the user:

Thank you very much for purchasing our products. The company will provide you with the best service.

1. Please keep the warranty and purchase invoice properly.
2. The warranty is completed by the selling unit, and the user and the sales unit sign and seal.
3. If there is any quality problem, please contact our technical service department or the maintenance Office of the company's resident office:
 - (1) Warranty period. Within one year from the date of purchase of the instrument, the company will provide free warranty.
 - (2) The free maintenance service during the warranty period is only responsible for the malfunction caused by the quality problems of the instruments under normal operation, excluding vulnerable parts.
 - (3) One of the following circumstances is not within the scope of free maintenance services.
 1. users can not provide warranty or purchase invoice unauthorized alteration. ◦
 2. because of failure to operate in accordance with instructions.
 - (4) If the quality problems beyond the warranty period or the damaged parts, the company will provide spare parts at the factory price for a long time, and charge the maintenance fee when necessary.

Guarantee proof:

Name		Model	
Manufacture date		Product number	
Date of purchase		Phone number	
Dealers (seal)			